



Con il fine di migliorare costantemente la qualità dei nostri prodotti, ci riserviamo il diritto di modificarne in qualsiasi momento le caratteristiche senza preavviso.

È responsabilità della spettabile clientela la costante verifica dei dati contenuti nei cataloghi.

Questo catalogo annulla e sostituisce i precedenti.

In order to constantly improve our products quality, we take the right to make changes to the catalogues at any time without notice.

Customers have the responsibility to continuously check all the information in the catalogues.

This catalogue cancels and replaces the previous ones.

SCAMBIATORI DI CALORE SERIE S
HEAT EXCHANGERS SERIES S

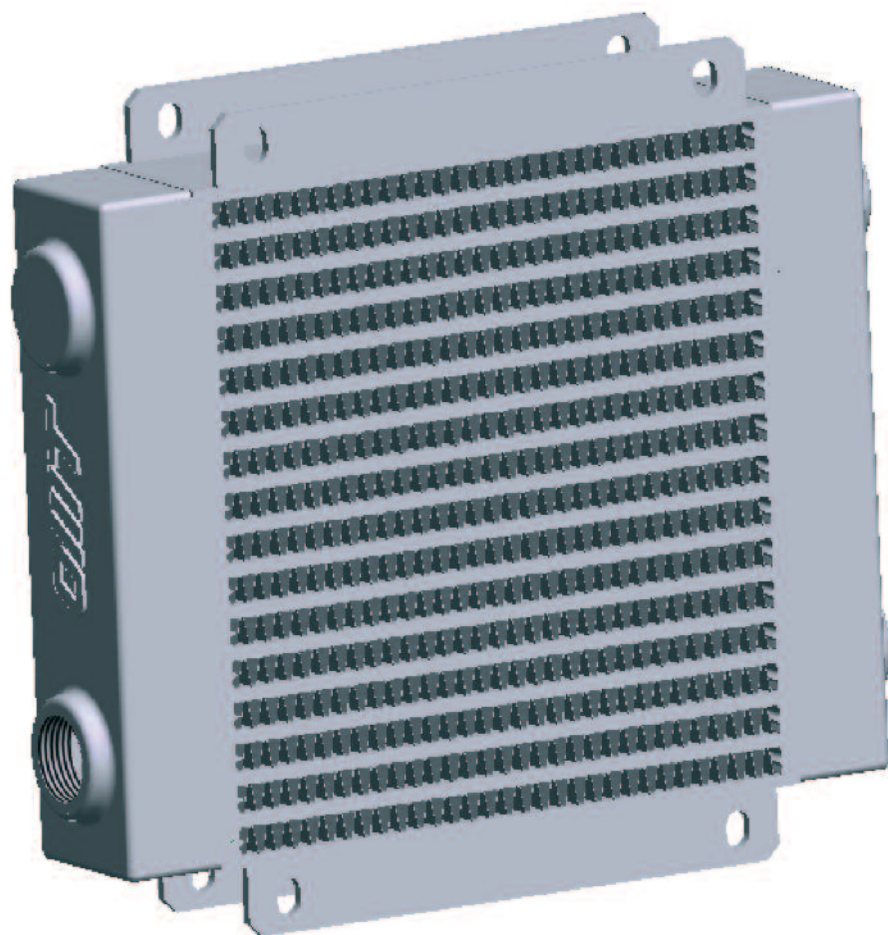

CARATTERISTICHE TECNICHE

TECHNICAL DATA

Specifiche pacco radiante

Materiale	Alluminio
Pressione di esercizio	25 bar
Pressione di collaudo	35 bar
Temperatura max d'esercizio	120 °C

Compatibilità con i fluidi

Oli minerali, hl, hlp, emulsioni acqua-olio.

Installazione

È consigliabile installare in parallelo allo scambiatore una valvola di By-pass, per proteggerlo durante la fase di avviamento.

Inoltre assicurarsi di non interporre ostacoli alla portata dell'aria.

Manutenzione

Pulizia lato olio

Lo sporco potrà essere eliminato con il flussaggio di un prodotto detergente o sgrassante compatibile con l'alluminio. Alla fine di tale operazione bisognerà ricorrere all'aria compressa per eliminare i residui che restano all'interno.

Pulizia lato aria

La pulizia dovrà essere effettuata mediante aria compressa o acqua. Durante tale operazione bisognerà prestare particolare attenzione alla direzione del getto per non rovinare le alette. Se lo sporco è causato da olio o da grasso, la pulizia potrà essere effettuata con un getto di vapore o di acqua calda. Durante tali operazioni il motore elettrico dovrà essere scollegato e adeguatamente protetto.

Radiating mass data

Material	Aluminium
Nominal pressure	25 bar
Test pressure	35 bar
Max temperature	120 °C

Fluid compatibility

Mineral oils, hl, hlp, water-oil emulsion.

Installation

We recommend to install a by-pass valve in parallel to the heat exchanger, for its protection during the starting up.

Make sure there is no obstacle to the air flow.

Maintenance

Oil side cleaning

Flushing with a detergent or a degreasing product compatible with aluminium, eliminates the dirt.

To remove the residuals, use compressed air.

Air side cleaning

It can be done by using compressed air or water and paying attention to the jet direction for not spoiling the vanes. If oil or grease has to be removed, clean with a jet of steam or hot water. Make sure that the electric motor is disconnected and properly protected.

MATERIALI UTILIZZATI

Ventola	Acciaio o plastica rinforzata
Convogliatore	Acciaio
Griglia di protezione	Acciaio o plastica rinforzata

MATERIALS

Fan	Steel or hard plastic
Fan case	Steel
Fan protection	Steel or hard plastic

Scambiatori di calore serie S

Serie Aria-Olio

Heat exchanger series S

Air-Oil version

Di seguito sono riportati tre differenti famiglie di scambiatori:

- serie "SS" standard
- serie "SS2" con doppio passaggio per portate ridotte, ma con maggiore potenzialità di scambio termico
- serie "SD" per portate elevate.

Sull'asse delle ascisse viene indicata la portata d'olio che attraversa lo scambiatore, espressa in (lt/min), mentre sulle ordinate è indicato il rendimento di dissipazione per ogni grado centigrado, espresso in (kcal/h °C); oppure in (kW/°C).

Il calore specifico di dissipazione (η) è dato dal rapporto tra la potenzialità termica (Q) dello scambiatore e la differenza di temperatura tra l'olio in entrata e la temperatura ambiente ($T^{\circ}\text{olio} - T^{\circ}\text{aria}$), con la seguente formula:

$$\eta = \frac{Q \text{ (kcal/h)}}{T^{\circ}\text{olio} - T^{\circ}\text{aria} \text{ (}^{\circ}\text{C)}}$$

Supponendo che lo scambiatore possa dissipare 3000 (kcal/h) e si abbia una differenza di temperatura ($T^{\circ}\text{olio} - T^{\circ}\text{aria}$) = 30(°C):

$$\eta = \frac{3000 \text{ (kcal/h)}}{30 \text{ (}^{\circ}\text{C)}} = 100 \text{ (kcal/h }^{\circ}\text{C)}$$

Nel caso in cui non sia nota la potenzialità termica (Q) dello scambiatore è possibile calcolarla empiricamente con la seguente formula:

$$Q = 0,40 \cdot V \cdot \Delta t_o$$

Dove:

V = portata olio in (lt/h)

Δt_o = differenza temp. tra olio in entrata e in uscita

0,40 è un valore approssimato o utilizzabile per olio idraulico (nel caso non se ne conoscano il peso specifico e il calore specifico).

$$\left[\begin{array}{l} 0,40 \text{ (kcal/lt}^{\circ}\text{C)} = c \cdot y \\ \text{dove:} \\ C = \text{calore specifico (kcal/kg}^{\circ}\text{C)} \\ Y = \text{peso specifico (kg/dm}^3\text{)} \end{array} \right]$$

Supponendo di avere una portata di 6000 (lt/h) e una differenza di temperatura tra olio in ingresso e olio in uscita (Δt_o) di 8 (°C) la potenzialità termica dello scambiatore è:

$$Q = 0,40 \cdot 6000 \cdot 8 = 19200 \text{ kcal/h}$$

Here you can find three different series of exchangers:

- series "SS" standard
- series "SS2" with double passage for reduced flows, but with bigger power of heat exchange
- series "SD" for high flows.

On the abscissas you can find the oil flow going through the exchanger, expressed in (lt/min), while on the ordinates you can find the dissipation performance for each centigrade degree, expressed in (kcal/h °C); or in (kW/°C).

The specific dissipation heat (η) is the result of the ratio between thermic power (Q) of the exchanger and the difference of the temperature between oil input and the ambient temperature (oil T° - air T°), using the following formula:

$$\eta = \frac{Q \text{ (kcal/h)}}{\text{oil } T^{\circ} - \text{air } T^{\circ} \text{ (}^{\circ}\text{C)}}$$

Supposing the exchanger can dissipate 3000 (kcal/h) and you have a temperature difference (oil T° - air T°) = 30 (°C):

$$\eta = \frac{3000 \text{ (kcal/h)}}{30 \text{ (}^{\circ}\text{C)}} = 100 \text{ (kcal/h }^{\circ}\text{C)}$$

When the thermic power (Q) of the exchanger is unknown, it is possible to calculate it empirically using the following formula:

$$Q = 0,40 \cdot V \cdot \Delta t_o$$

Where:

V = oil flow in (lt/h)

Δt_o = temperature difference between oil in and out

0,40 is an approximate value or it can be used for hydraulic oil (when specific weight and specific heat are unknown).

$$\left[\begin{array}{l} 0,40 \text{ (kcal/lt}^{\circ}\text{C)} = c \cdot y \\ \text{dove:} \\ C = \text{specific heat (kcal/kg}^{\circ}\text{C)} \\ Y = \text{specific weight (kg/dm}^3\text{)} \end{array} \right]$$

Supposing the flow is 6000 (lt/h) and the difference between oil in and out (Δt_o) is 8 (°C) the thermic power of the exchanger is:

$$Q = 0,40 \cdot 6000 \cdot 8 = 19200 \text{ kcal/h}$$

Le curve riportate a catalogo sono valide dal momento in cui si aziona il gruppo di raffreddamento.

La gamma OMT prevede diversi tipi di motorizzazione. Spazia dal motore in C.A. monofase, trifase e trifase unificato B14, a quello in C.C. 12-24V, oltre alla possibilità della predisposizione per il motore idraulico. È consigliato l'utilizzo della tipologia B14 nel momento in cui l'apparecchio ha un funzionamento continuo.

The above curves are valid when the cooler element is activated.

OMT range offers various types of motors. It ranges from C.A. single-phase, three-phase and B14 standardized three-phase motor to C.C. 12-24V motor, in addition to the possibility of the prearrangement for hydraulic motor. We advice the use of B14 type when the equipment runs continuously.

Scambiatore tipo SS10 Serie Aria-Olio Heat exchanger series SS10 Air-Oil version

CARATTERISTICHE TECNICHE DEL GRUPPO DI VENTILAZIONE TECHNICAL FEATURES

Tipologia Type	Frequenza Frequency Hz	Tensione Voltage V	N° Giri/min RPM	Potenza Power kW	Diam. Ventola Ø FAN (mm)	dB (A)	L (mm)	Q air (m³/h)	Cap. (lt)	Peso Weight (kg)	IP
01	50/60	230	2650/3000	0.050/0.046	170	63	125	500	0.28	6	44
03	50/60	400	2750/3100	0.045/0.043	170	63	125	500	0.28	6	44
12	DC	12	4000	0.080	167	64	158	550	0.28	5	65
24	DC	24	4100	0.080	167	64	158	550	0.28	5	65

Portata olio consigliata da 5 a 40 (lt/min)
Suggested oil flow from 5 to 40 (lt/min)

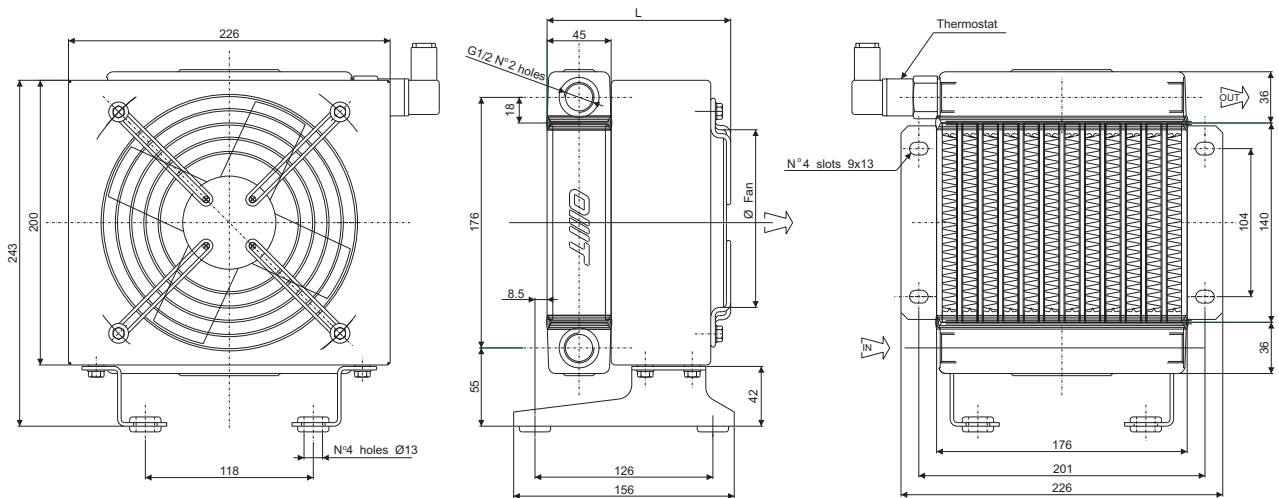

Coefficiente di correzione Correction factor

CST	10	15	20	32	40	50	60	80	100	200
F	0.51	0.66	0.76	1	1.22	1.4	1.6	1.9	2.1	3.4

Diagramma di rendimento Performance diagram



Diagramma perdite di carico (32 cst) Pressure drop diagram (32 cst)



Scambiatore tipo SS15 Serie Aria-Olio Heat exchanger series SS15 Air-Oil version

CARATTERISTICHE TECNICHE DEL GRUPPO DI VENTILAZIONE TECHNICAL FEATURES

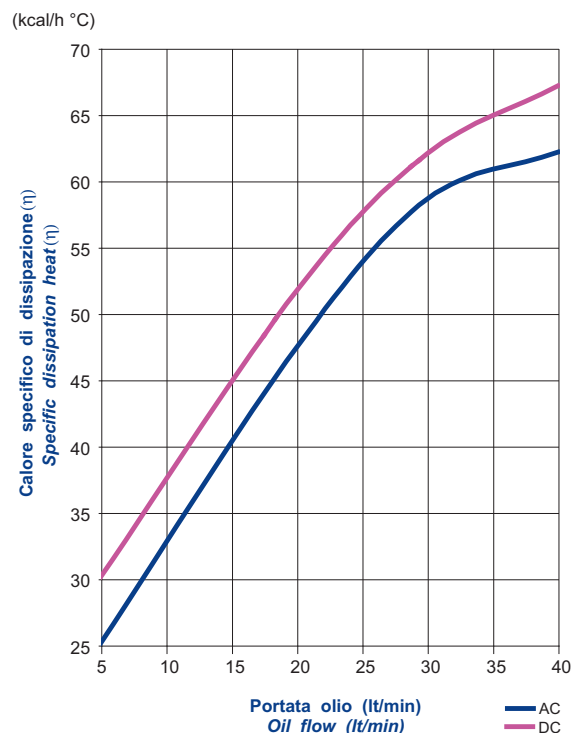
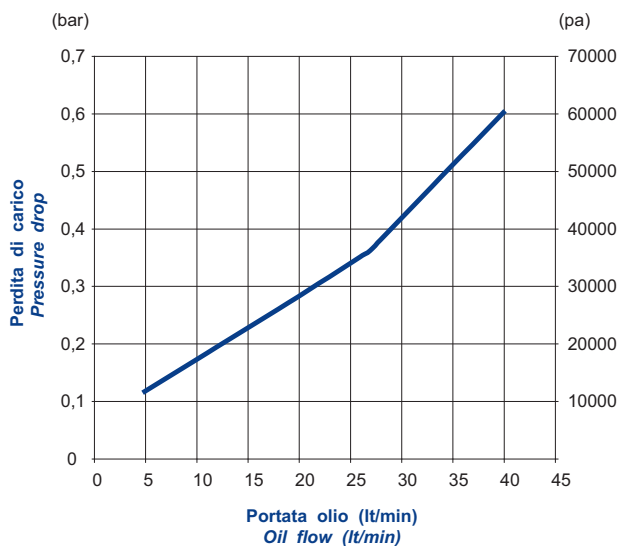
Tipologia Type	Frequenza Frequency Hz	Tensione Voltage V	N° Giri/min RPM	Potenza Power kW	Diam. Ventola Ø FAN (mm)	dB (A)	L (mm)	Q air (m³/h)	Cap. (lt)	Peso Weight (kg)	IP
01	50/60	230	2600/2900	0.064/0.078	200	67	152	890	0.48	7	44
03	50/60	400	2600/2900	0.068/0.070	200	67	152	890	0.48	7	44
14	50/60	230/400	1370/1650	0.25	200	67	346	700	0.48	10	55
12	DC	12	3100	0.100	225	66	158	1200	0.48	6.5	65
24	DC	24	3000	0.100	225	66	158	1200	0.48	6.5	65
G2	-	-	-	-	200	-	-	-	-	6	-

Portata olio consigliata da 20 a 80 (lt/min)
Suggested oil flow from 20 to 80 (lt/min)

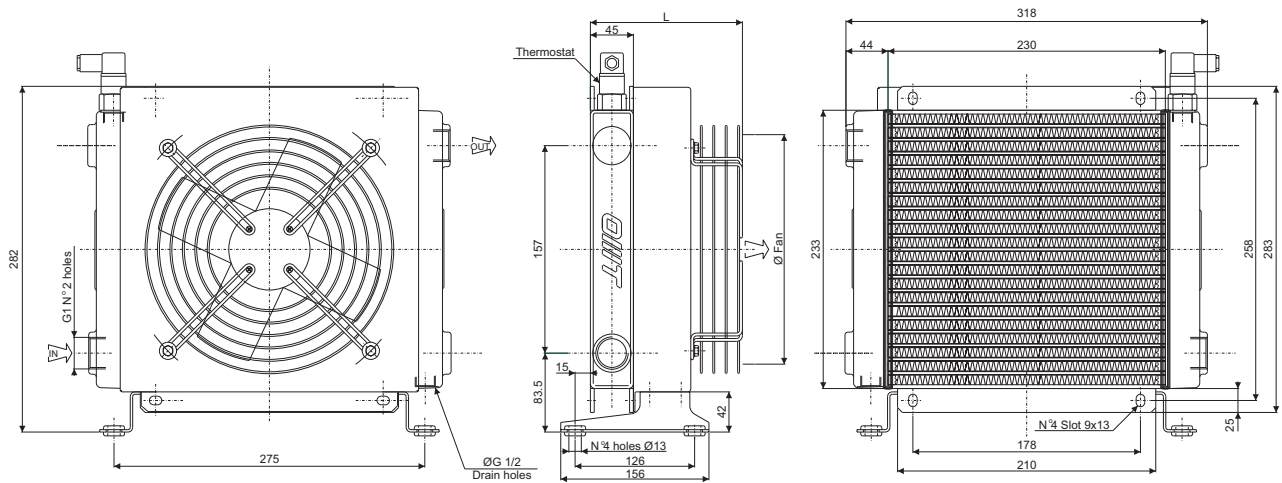

Coefficiente di correzione Correction factor

CST	10	15	20	32	40	50	60	80	100	200
F	0.51	0.66	0.76	1	1.22	1.4	1.6	1.9	2.1	3.4

Diagramma perdite di carico (32 cst) Pressure drop diagram (32 cst)



Diagramma di rendimento Performance diagram



Scambiatore tipo SS20 Serie Aria-Olio Heat exchanger series SS20 Air-Oil version

CARATTERISTICHE TECNICHE DEL GRUPPO DI VENTILAZIONE TECHNICAL FEATURES

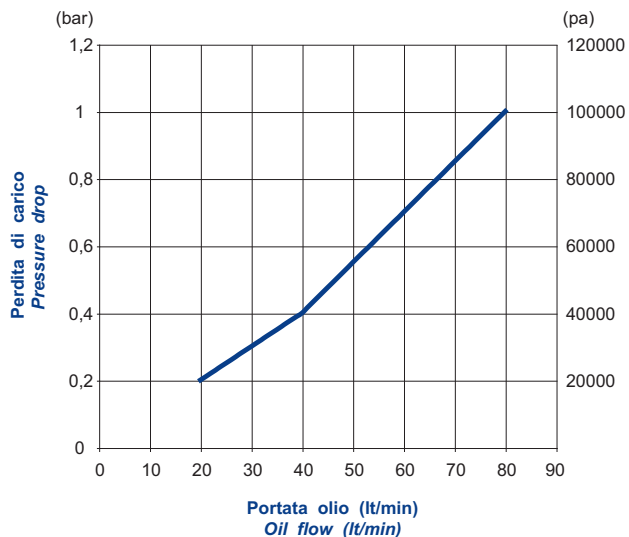
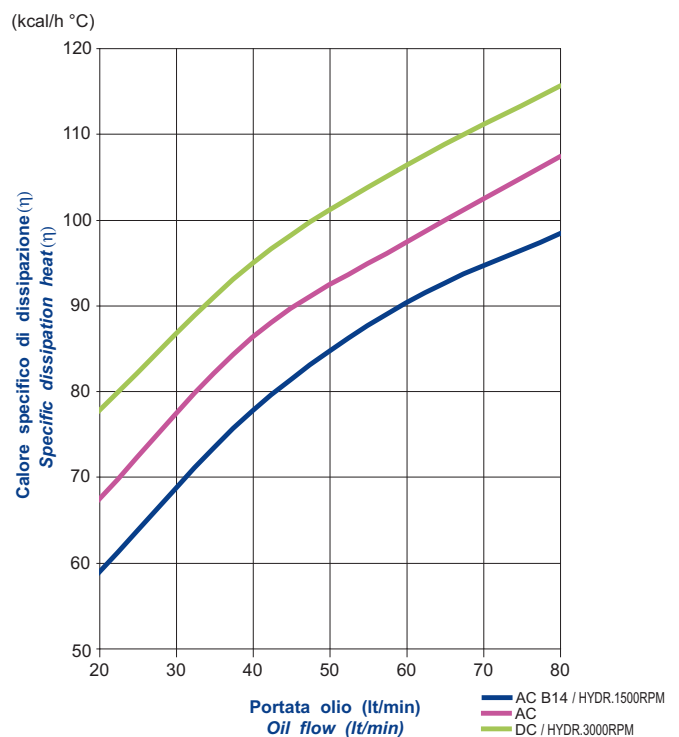
Tipologia Type	Frequenza Frequency Hz	Tensione Voltage V	N° Giri/min RPM	Potenza Power kW	Diam. Ventola Ø FAN (mm)	dB (A)	L (mm)	Q air (m ³ /h)	Cap. (lt)	Peso Weight (kg)	IP
01	50/60	230	2600/2900	0.064/0.078	200	67	170	890	0.68	8	4
03	50/60	400	2600/2900	0.068/0.070	200	67	170	890	0.68	8	44
14	50/60	230/400	1370/1650	0.25	200	67	364	700	0.68	11	55
12	DC	12	3100	0.100	225	66	176	1200	0.68	7	65
24	DC	24	3000	0.100	225	66	176	1200	0.68	7	65
G2	-	-	-	-	200	-	-	-	-	7	-

Portata olio consigliata da 30 a 100 (lt/min)
Suggested oil flow from 30 to 100 (lt/min)

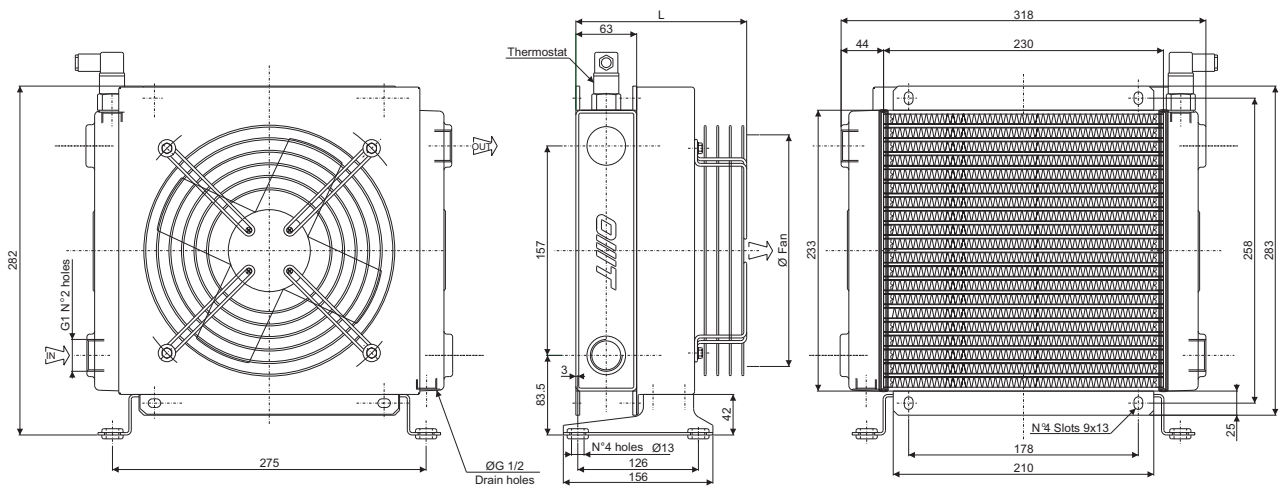

Coefficiente di correzione Correction factor

CST	10	15	20	32	40	50	60	80	100	200
F	0.51	0.66	0.76	1	1.22	1.4	1.6	1.9	2.1	3.4

Diagramma di rendimento Performance diagram



Diagramma perdite di carico (32 cst) Pressure drop diagram (32 cst)



Scambiatore tipo SS24 Serie Aria-Olio Heat exchanger series SS24 Air-Oil version

CARATTERISTICHE TECNICHE DEL GRUPPO DI VENTILAZIONE TECHNICAL FEATURES

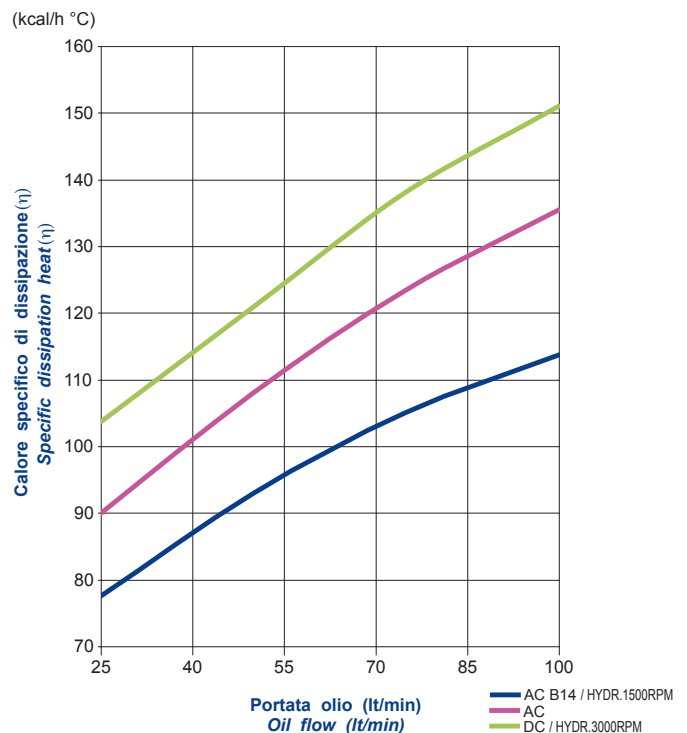
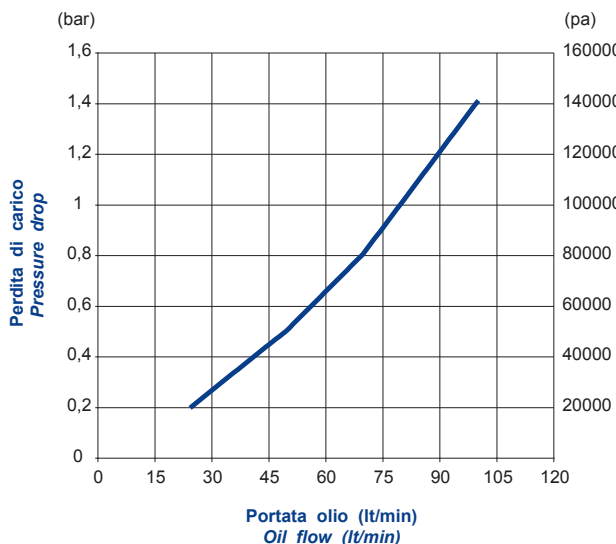
Tipologia Type	Frequenza Frequency Hz	Tensione Voltage V	N° Giri/min RPM	Potenza Power kW	Diam. Ventola Ø FAN (mm)	dB (A)	L (mm)	Q air (m ³ /h)	Cap. (lt)	Peso Weight (kg)	IP
01	50/60	230	2550/2750	0.11/0.16	250	68	169	1780	0.9	11	44
03	50/60	400	2500/2650	0.10/0.14	250	68	169	1780	0.9	11	44
14	50/60	230/400	1370	0.25	250	68	364	1500	0.9	15.5	55
12	DC	12	3000	0.100	280	66	176	1600	0.9	10	65
24	DC	24	3000	0.100	280	66	176	1600	0.9	10	65
G2	-	-	-	-	250	-	-	-	-	10	-

Portata olio consigliata da 40 a 120 (lt/min)
Suggested oil flow from 40 to 120 (lt/min)

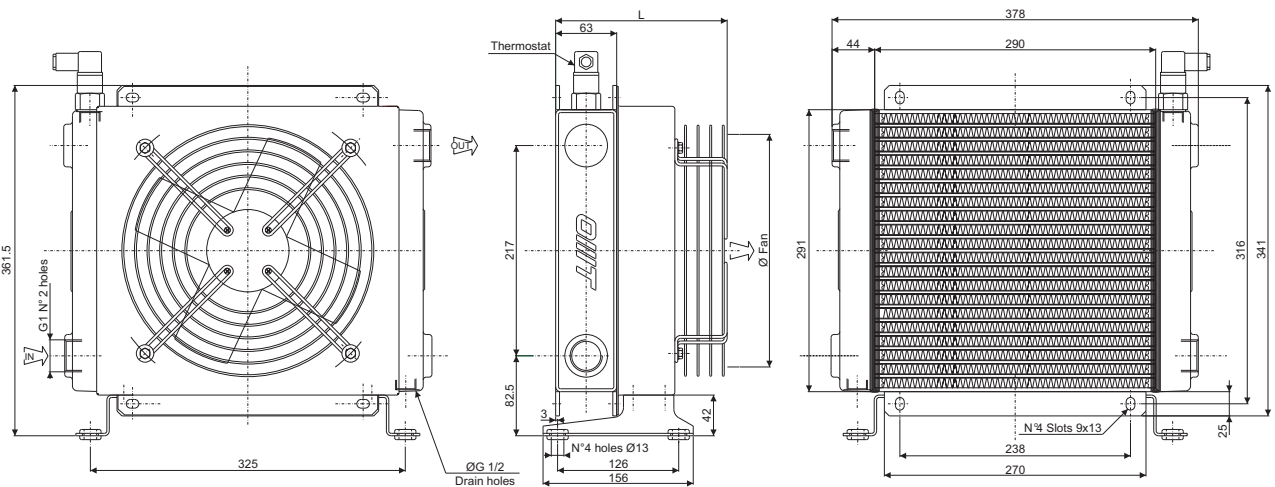

Coefficiente di correzione Correction factor

CST	10	15	20	32	40	50	60	80	100	200
F	0.51	0.66	0.76	1	1.22	1.4	1.6	1.9	2.1	3.4

Diagramma di rendimento Performance diagram



Diagramma perdite di carico (32 cst) Pressure drop diagram (32 cst)



Scambiatore tipo SS30 Serie Aria-Olio Heat exchanger series SS30 Air-Oil version

CARATTERISTICHE TECNICHE DEL GRUPPO DI VENTILAZIONE TECHNICAL FEATURES

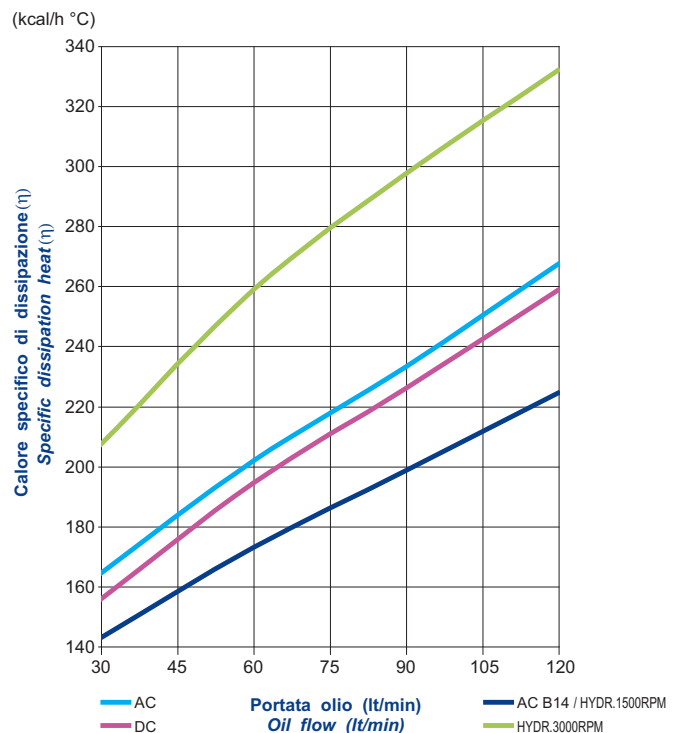
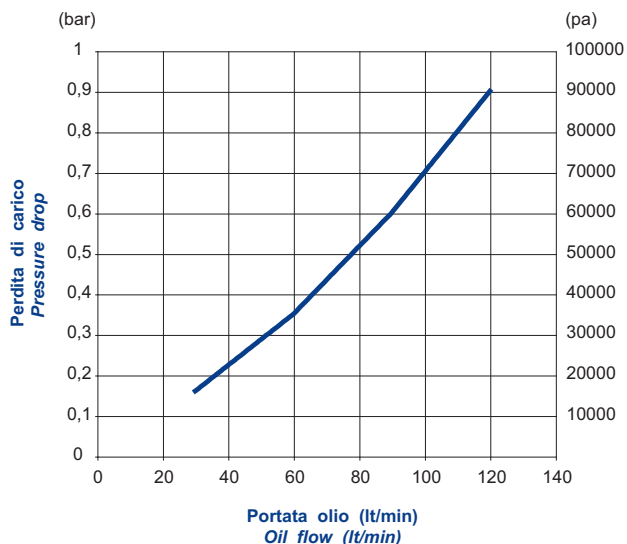
Tipologia Type	Frequenza Frequency Hz	Tensione Voltage V	N° Giri/min RPM	Potenza Power kW	Diam. Ventola Ø FAN (mm)	dB (A)	L (mm)	Q air (m ³ /h)	Cap. (lt)	Peso Weight (kg)	IP
01	50/60	230	2700/3000	0.23/0.35	300	69	183	3290	1.5	15	44
03	50/60	400	2600/2850	0.19/0.27	300	69	183	3290	1.5	15	44
14	50/60	230/400	1390	0.37	300	69	404	2000	1.5	20	55
12	DC	12	3000	0.175	305	67	219	2300	1.5	14	65
24	DC	24	3000	0.175	305	67	219	2300	1.5	14	65
G2	-	-	-	-	300	-	238	-	1.5	14.5	-

Portata olio consigliata da 35 a 140 (lt/min)
Suggested oil flow from 35 to 140 (lt/min)

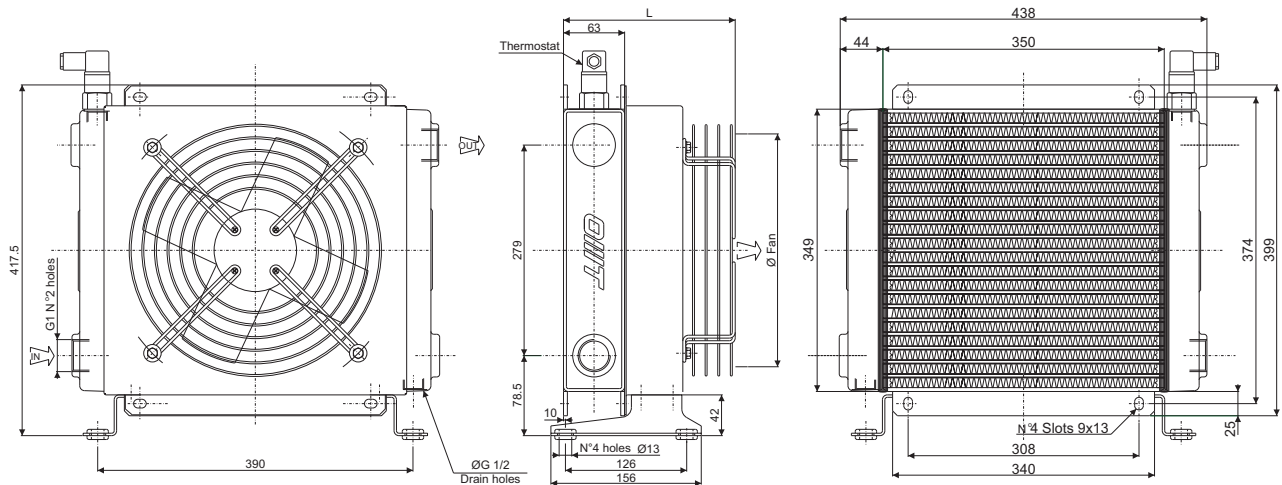

Coefficiente di correzione Correction factor

CST	10	15	20	32	40	50	60	80	100	200
F	0.51	0.66	0.76	1	1.22	1.4	1.6	1.9	2.1	3.4

Diagramma perdite di carico (32 cst) Pressure drop diagram (32 cst)



Diagramma di rendimento Performance diagram



Scambiatore tipo SS40 Serie Aria-Olio Heat exchanger series SS40 Air-Oil version

CARATTERISTICHE TECNICHE DEL GRUPPO DI VENTILAZIONE TECHNICAL FEATURES

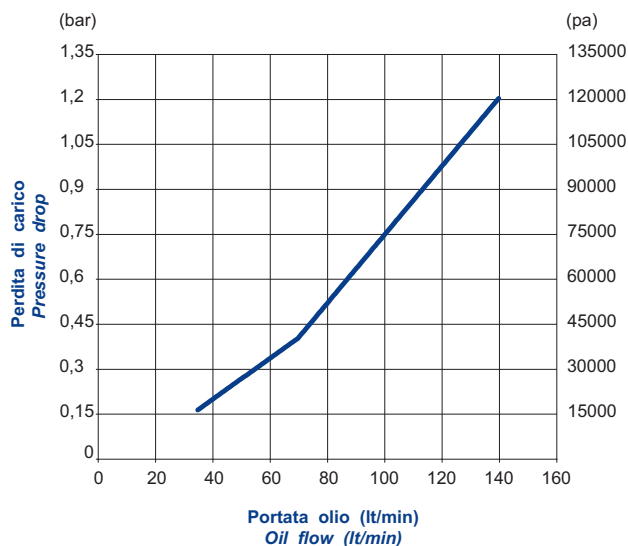
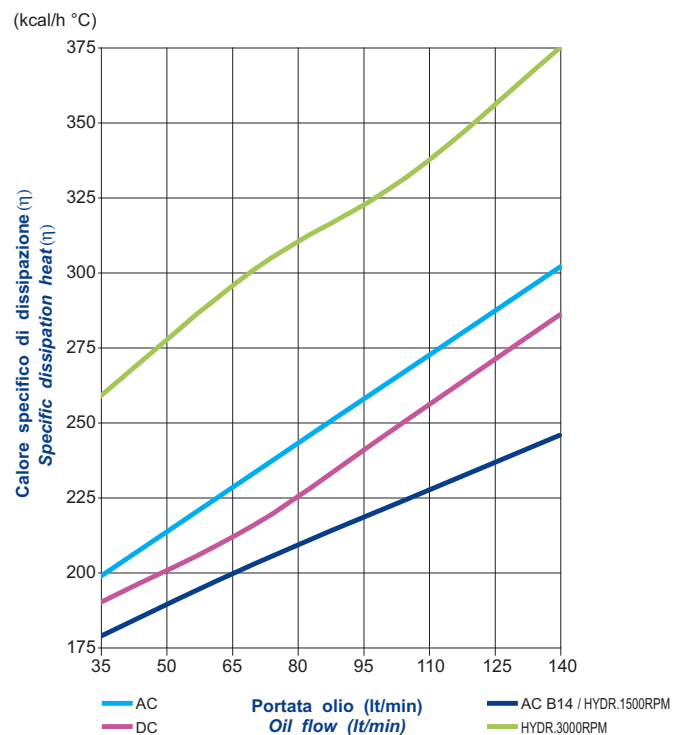
Tipologia Type	Frequenza Frequency Hz	Tensione Voltage V	N° Giri/min RPM	Potenza Power kW	Diam. Ventola Ø FAN (mm)	dB (A)	L (mm)	Q air (m ³ /h)	Cap. (lt)	Peso Weight (kg)	IP
01	50/60	230	1440/1700	0.16/0.24	400	71	223	4000	2.6	21	44
03	50/60	400	1450/1690	0.13/0.18	400	71	223	4000	2.6	21	44
14	50/60	230/400	1430	0.55	400	71	446	4000	2.6	25	55
12	DC	12	2500	0.200	385	69	229	3500	2.6	20	65
24	DC	24	2500	0.200	385	71	229	3500	2.6	20	65
G2	-	-	-	-	400	-	248	-	2.6	19	-

Portata olio consigliata da 40 a 160 (lt/min)
Suggested oil flow from 40 to 160 (lt/min)

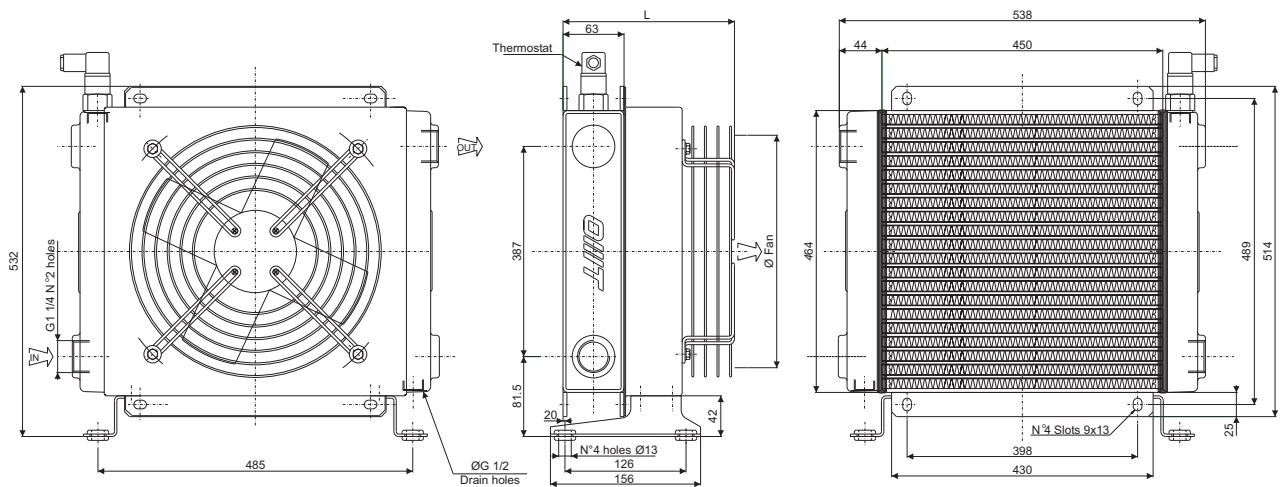

Coefficiente di correzione Correction factor

CST	10	15	20	32	40	50	60	80	100	200
F	0.51	0.66	0.76	1	1.22	1.4	1.6	1.9	2.1	3.4

Diagramma perdite di carico (32 cst) Pressure drop diagram (32 cst)



Diagramma di rendimento Performance diagram



Scambiatore tipo SS50 Serie Aria-Olio Heat exchanger series SS50 Air-Oil version

CARATTERISTICHE TECNICHE DEL GRUPPO DI VENTILAZIONE TECHNICAL FEATURES

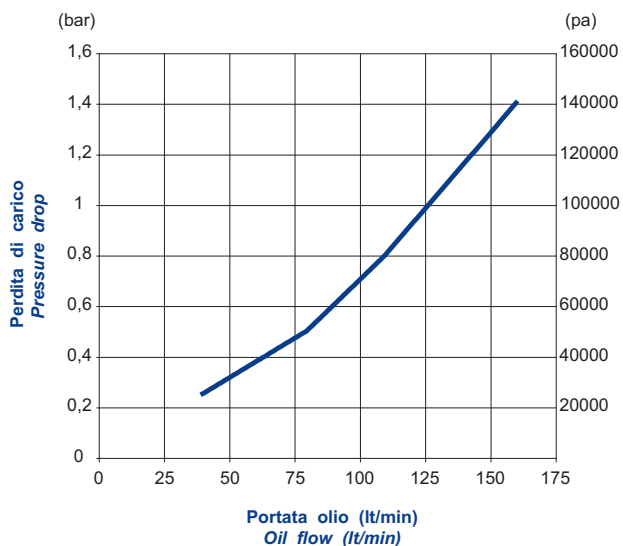
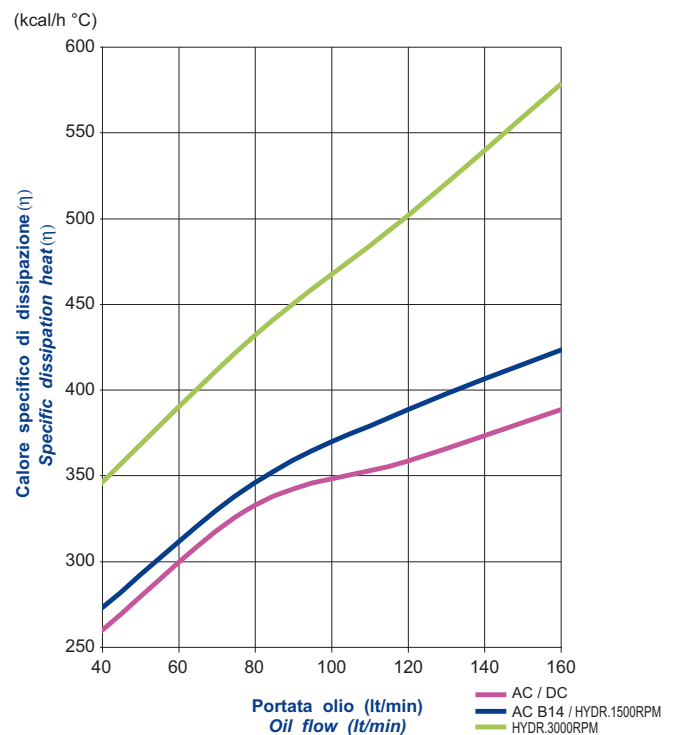
Tipologia Type	Frequenza Frequency Hz	Tensione Voltage V	N° Giri/min RPM	Potenza Power kW	Diam. Ventola Ø FAN (mm)	dB (A)	L (mm)	Q air (m³/h)	Cap. (lt)	Peso Weight (kg)	IP
03	50/60	230/400	1380/1840	0.20/0.28	450	73	290	6830	4.9	27	44
14	50/60	230/400	1430	0.75	450	73	446	6830	4.9	30	55
12	DC	12	3000	0.145 (x2)	280	73	207	4200	4.9	24	65
24	DC	24	3000	0.145 (x2)	280	73	207	4200	4.9	24	65
G2	-	-	-	-	450	-	248	-	4.9	23	-

Portata olio consigliata da 50 a 180 (lt/min)
Suggested oil flow from 50 to 180 (lt/min)

(x2) = doppio motore
(x2) = double engine

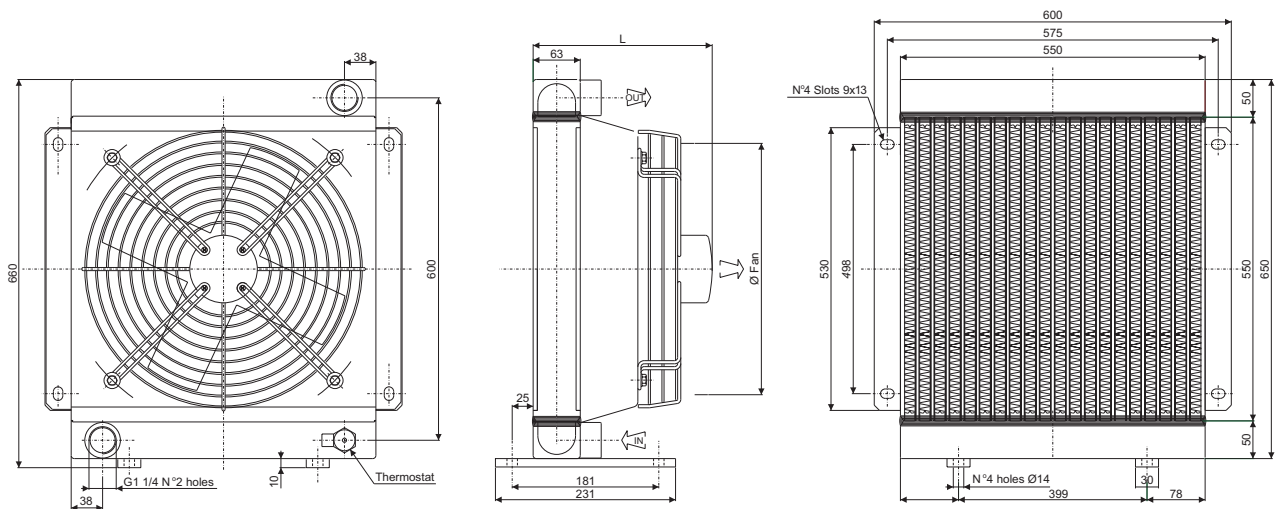

Coefficiente di correzione Correction factor

CST	10	15	20	32	40	50	60	80	100	200
F	0.51	0.66	0.76	1	1.22	1.4	1.6	1.9	2.1	3.4

Diagramma perdite di carico (32 cst) Pressure drop diagram (32 cst)



Diagramma di rendimento Performance diagram



Scambiatore tipo SS215 2pass Serie Aria-Olio

Heat exchanger series SS215 2pass Air-Oil version

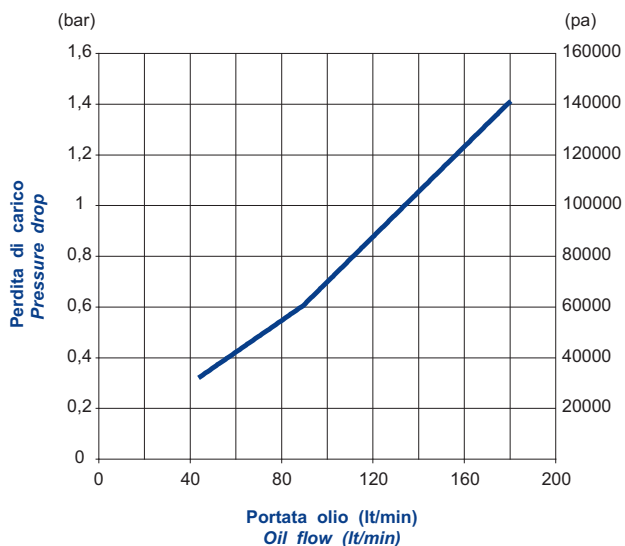
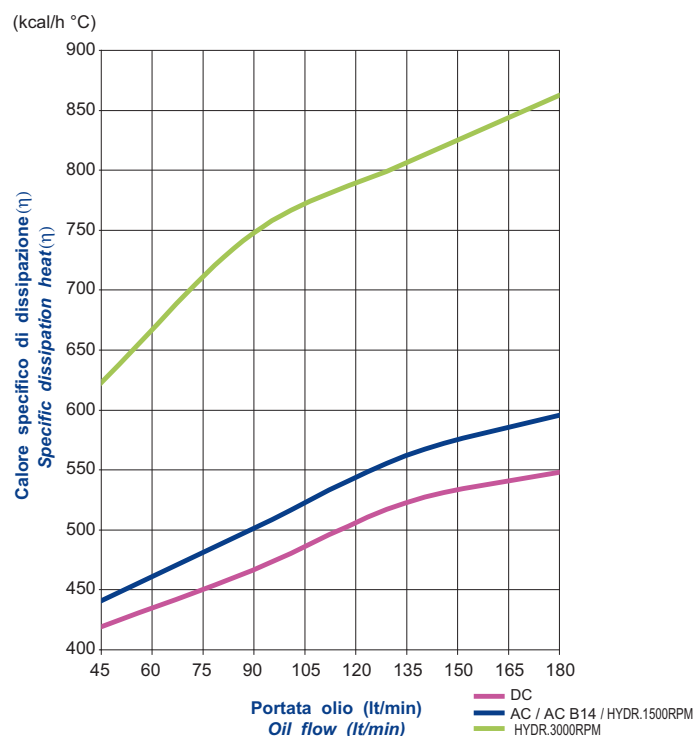
CARATTERISTICHE TECNICHE DEL GRUPPO DI VENTILAZIONE TECHNICAL FEATURES

Tipologia Type	Frequenza Frequency Hz	Tensione Voltage V	N° Giri/min RPM	Potenza Power kW	Diam. Ventola Ø FAN (mm)	dB (A)	L (mm)	Q air (m³/h)	Cap. (lt)	Peso Weight (kg)	IP
01	50/60	230	2600/2900	0.064/0.078	200	67	152	890	0.48	7	44
03	50/60	400	2600/2900	0.068/0.070	200	67	152	890	0.48	7	44
14	50/60	230/400	1370/1650	0.25	200	67	346	700	0.48	10	55
12	DC	12	3100	0.100	225	66	158	1200	0.48	6.5	65
24	DC	24	3000	0.100	225	66	158	1200	0.48	6.5	65
G2	-	-	-	-	200	-	-	-	-	6	-

Portata olio consigliata da 5 a 40 (lt/min)
Suggested oil flow from 5 to 40 (lt/min)

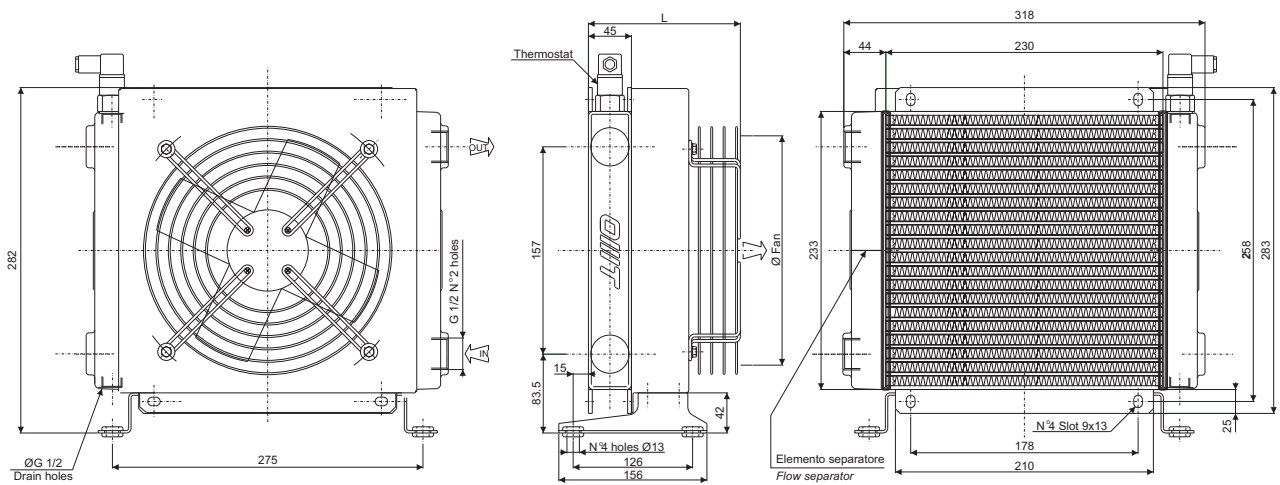

Coefficiente di correzione Correction factor

CST	10	15	20	32	40	50	60	80	100	200
F	0.51	0.66	0.76	1	1.22	1.4	1.6	1.9	2.1	3.4

Diagramma di rendimento Performance diagram



Diagramma perdite di carico (32 cst) Pressure drop diagram (32 cst)



Scambiatore tipo SS220 2pass Serie Aria-Olio

Heat exchanger series SS220 2pass Air-Oil version

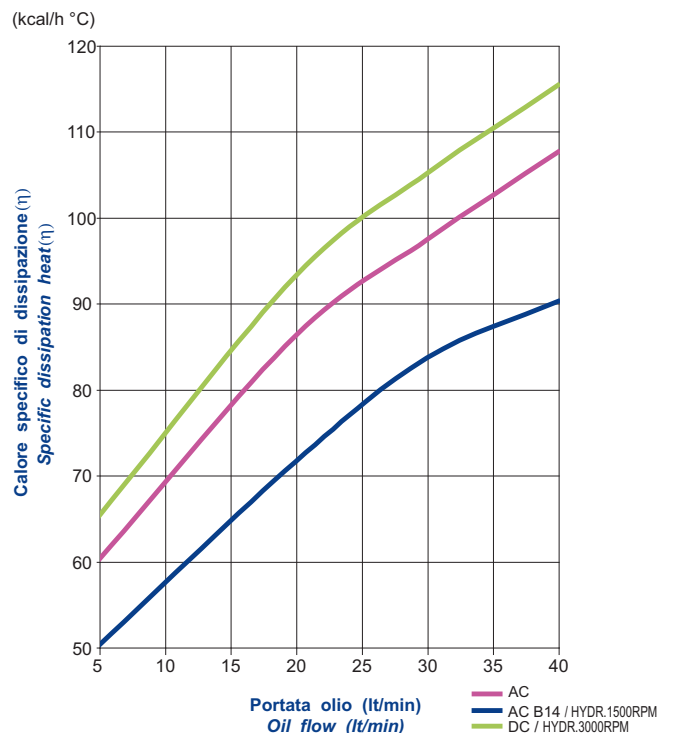
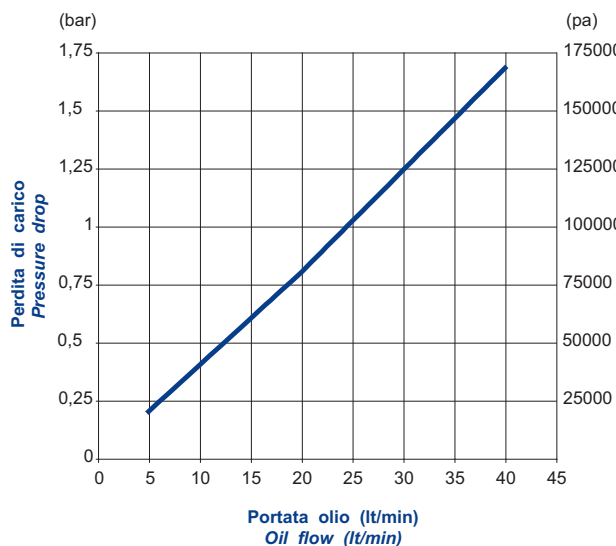
CARATTERISTICHE TECNICHE DEL GRUPPO DI VENTILAZIONE TECHNICAL FEATURES

Tipologia Type	Frequenza Frequency Hz	Tensione Voltage V	N° Giri/min RPM	Potenza Power kW	Diam. Ventola Ø FAN (mm)	dB (A)	L (mm)	Q air (m³/h)	Cap. (lt)	Peso Weight (kg)	IP
01	50/60	230	2600/2900	0.064/0.078	200	67	170	890	0.68	8	44
03	50/60	400	2600/2900	0.068/0.070	200	67	170	890	0.68	8	44
14	50/60	230/400	1370/1650	0.25	200	67	364	700	0.68	11	55
12	DC	12	3100	0.100	225	66	176	1200	0.68	7	65
24	DC	24	3000	0.100	225	66	176	1200	0.68	7	65
G2	-	-	-	-	200	-	-	-	-	7	-

Portata olio consigliata da 5 a 40 (lt/min)
Suggested oil flow from 5 to 40 (lt/min)

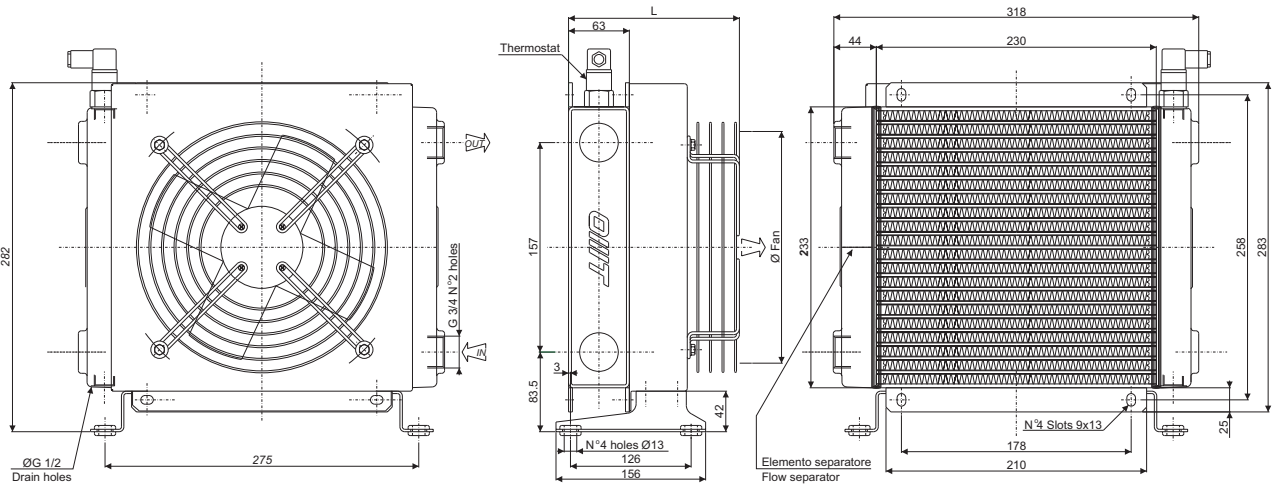

Coefficiente di correzione Correction factor

CST	10	15	20	32	40	50	60	80	100	200
F	0.51	0.66	0.76	1	1.22	1.4	1.6	1.9	2.1	3.4

Diagramma di rendimento Performance diagram



Diagramma perdite di carico (32 cst) Pressure drop diagram (32 cst)



Scambiatore tipo SS224 2pass Serie Aria-Olio

Heat exchanger series SS224 2pass Air-Oil version

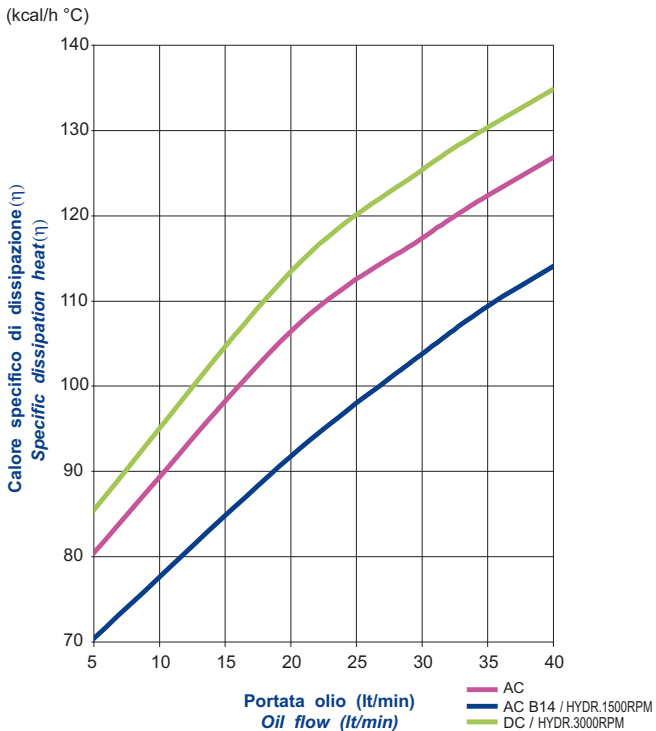
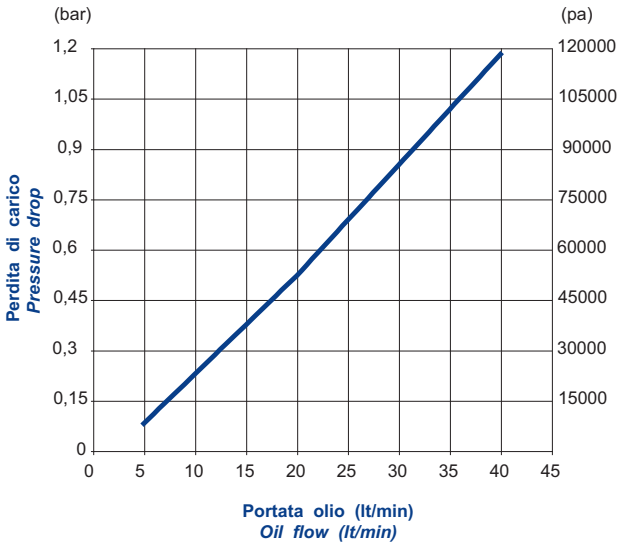
CARATTERISTICHE TECNICHE DEL GRUPPO DI VENTILAZIONE TECHNICAL FEATURES

Tipologia Type	Frequenza Frequency Hz	Tensione Voltage V	N° Giri/min RPM	Potenza Power kW	Diam. Ventola Ø FAN (mm)	dB (A)	L (mm)	Q air (m³/h)	Cap. (lt)	Peso Weight (kg)	IP
01	50/60	230	2550/2750	0.11/0.16	250	67	169	1780	0.9	11	44
03	50/60	400	2500/2650	0.10/0.14	250	67	169	1780	0.9	11	44
14	50/60	230/400	1370	0.25	250	67	364	1500	0.9	15.5	55
12	DC	12	3000	0.100	280	66	176	1600	0.9	10	65
24	DC	24	3000	0.100	280	66	176	1600	0.9	10	65
G2	-	-	-	-	250	-	-	-	-	10	-

Portata olio consigliata da 10 a 60 (lt/min)
Suggested oil flow from 10 to 60 (lt/min)

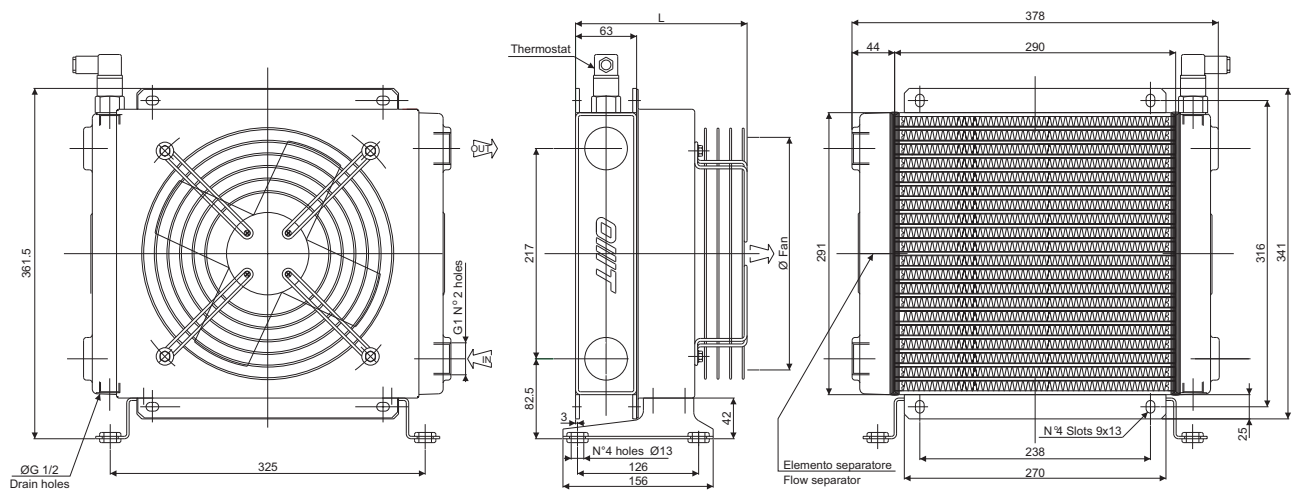

Coefficiente di correzione Correction factor

CST	10	15	20	32	40	50	60	80	100	200
F	0.51	0.66	0.76	1	1.22	1.4	1.6	1.9	2.1	3.4

Diagramma di rendimento Performance diagram



Diagramma perdite di carico (32 cst) Pressure drop diagram (32 cst)



Scambiatore tipo SS230 2pass Serie Aria-Olio

Heat exchanger series SS230 2pass Air-Oil version

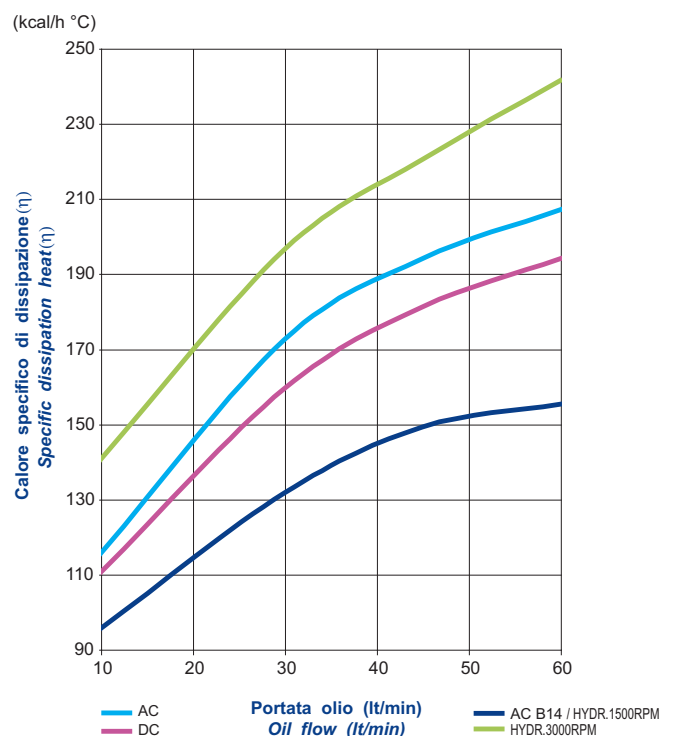
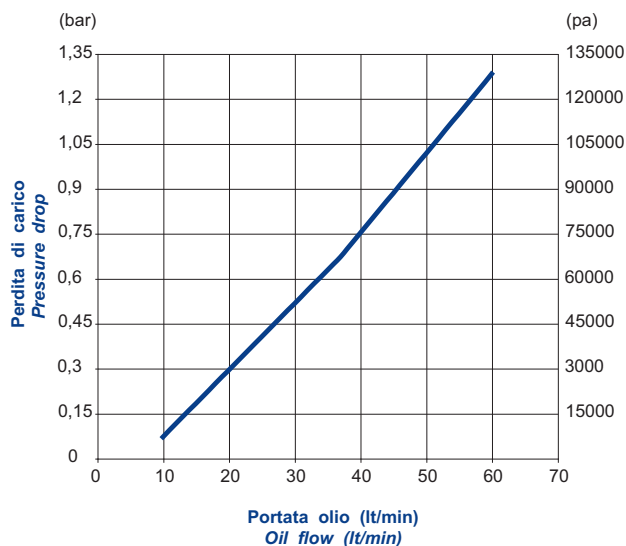
CARATTERISTICHE TECNICHE DEL GRUPPO DI VENTILAZIONE TECHNICAL FEATURES

Tipologia Type	Frequenza Frequency Hz	Tensione Voltage V	N° Giri/min RPM	Potenza Power kW	Diam. Ventola Ø FAN (mm)	dB (A)	L (mm)	Q air (m³/h)	Cap. (lt)	Peso Weight (kg)	IP
01	50/60	230	2700/3000	0.23/0.35	300	69	183	3290	1.5	15	44
03	50/60	400	2600/2850	0.19/0.27	300	69	183	3290	1.5	15	44
14	50/60	230/400	1390	0.37	300	69	404	2000	1.5	20	55
12	DC	12	3000	0.175	305	67	219	2300	1.5	14	65
24	DC	24	3000	0.175	305	67	219	2300	1.5	14	65
G2	-	-	-	-	300	-	238	-	1.5	14.5	-

Portata olio consigliata da 15 a 60 (lt/min)
Suggested oil flow from 15 to 60 (lt/min)

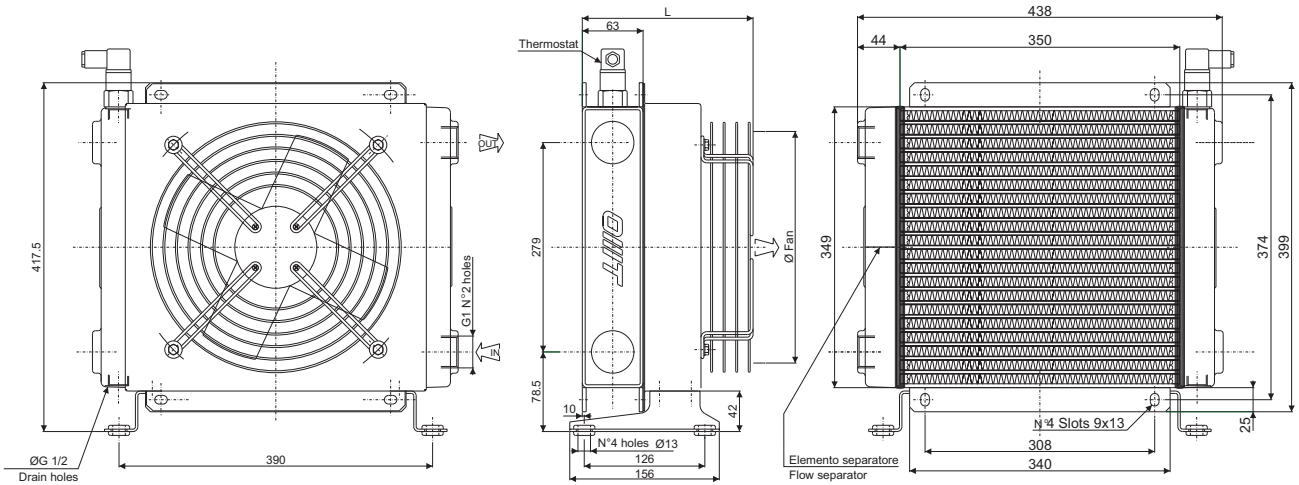

Coefficiente di correzione Correction factor

CST	10	15	20	32	40	50	60	80	100	200
F	0.51	0.66	0.76	1	1.22	1.4	1.6	1.9	2.1	3.4

Diagramma di rendimento Performance diagram



Diagramma perdite di carico (32 cst) Pressure drop diagram (32 cst)



Scambiatore tipo SS240 2pass Serie Aria-Olio

Heat exchanger series SS240 2pass Air-Oil version

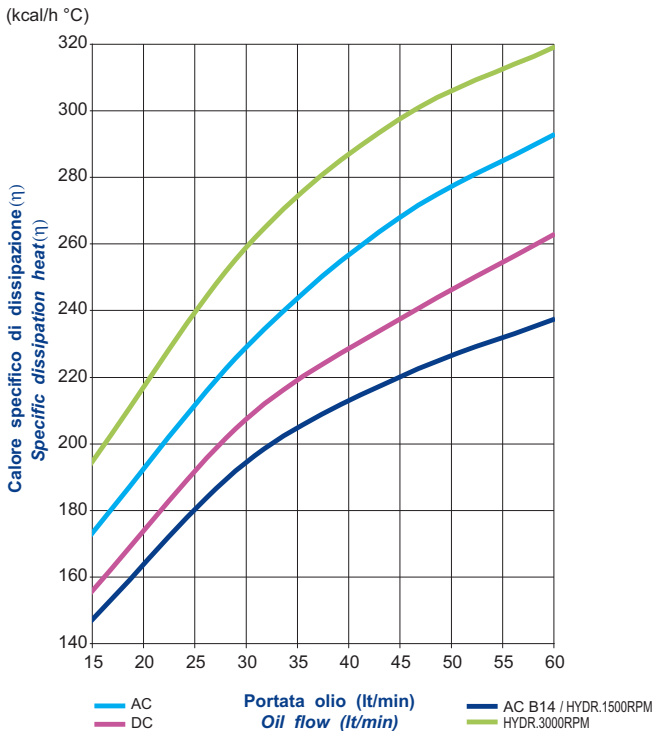
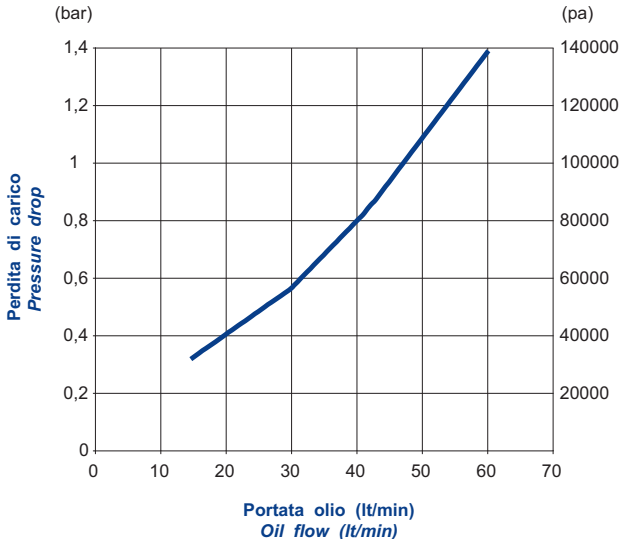
CARATTERISTICHE TECNICHE DEL GRUPPO DI VENTILAZIONE TECHNICAL FEATURES

Tipologia Type	Frequenza Frequency Hz	Tensione Voltage V	N° Giri/min RPM	Potenza Power kW	Diam. Ventola Ø FAN (mm)	dB (A)	L (mm)	Q air (m³/h)	Cap. (lt)	Peso Weight (kg)	IP
01	50/60	230	1440/1700	0.16/0.24	400	71	223	4000	2.6	21	44
03	50/60	400	1450/1690	0.13/0.18	400	71	223	4000	2.6	21	44
14	50/60	230/400	1430	0.55	400	71	446	4000	2.6	25	55
12	DC	12	2500	0.200	385	69	229	3500	2.6	20	65
24	DC	24	2500	0.200	385	71	229	3500	2.6	20	65
G2	-	-	-	-	400	-	248	-	2.6	19	-

Portata olio consigliata da 20 a 80 (lt/min)
Suggested oil flow from 20 to 80 (lt/min)

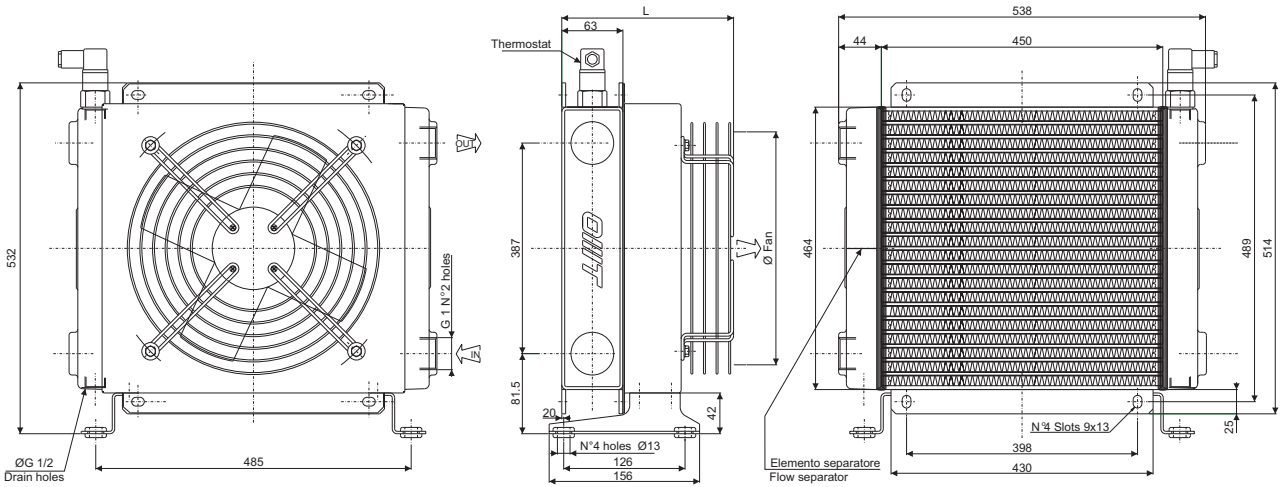

Coefficiente di correzione Correction factor

CST	10	15	20	32	40	50	60	80	100	200
F	0.51	0.66	0.76	1	1.22	1.4	1.6	1.9	2.1	3.4

Diagramma di rendimento Performance diagram



Diagramma perdite di carico (32 cst) Pressure drop diagram (32 cst)



Scambiatore tipo SD20 Serie Aria-Olio Heat exchanger series SD20 Air-Oil version

CARATTERISTICHE TECNICHE DEL GRUPPO DI VENTILAZIONE TECHNICAL FEATURES

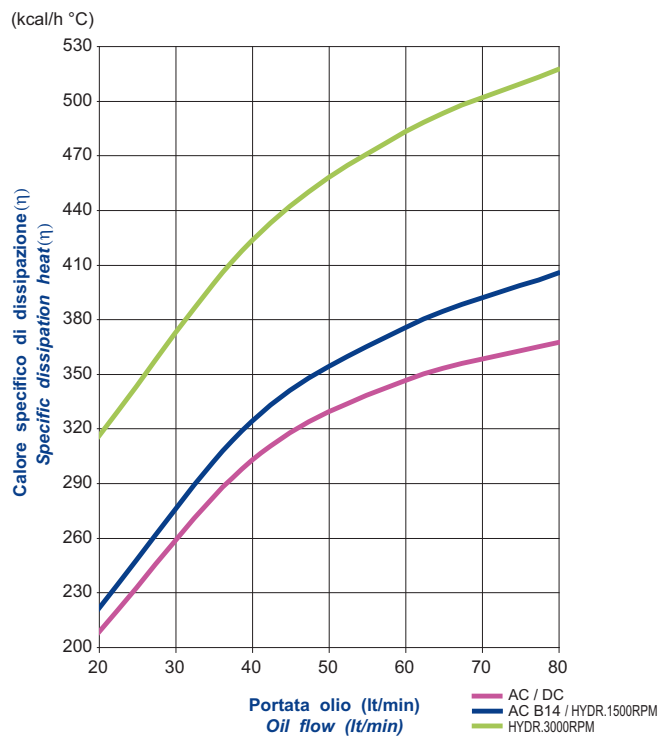
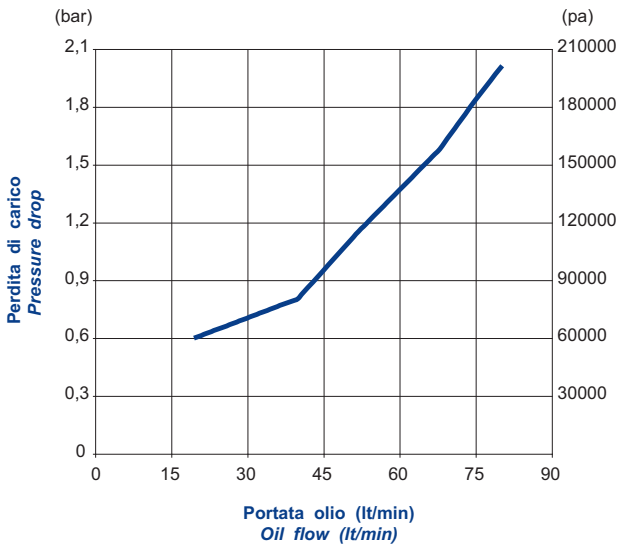
Tipologia Type	Frequenza Frequency Hz	Tensione Voltage V	N° Giri/min RPM	Potenza Power kW	Diam. Ventola Ø FAN (mm)	dB (A)	L (mm)	Q air (m³/h)	Cap. (lt)	Peso Weight (kg)	IP
01	50/60	230	2600/2900	0.064/0.078 (x2)	200	67	170	1780	1.3	17	44
03	50/60	400	2600/2900	0.068/0.070 (x2)	200	67	170	1780	1.3	17	44
14	50/60	230/400	1370/1650	0.25 (x2)	200	67	364	1400	1.3	23	55
12	DC	12	3100	0.100 (x2)	225	66	176	2400	1.3	15	65
24	DC	24	3000	0.100 (x2)	225	66	176	2400	1.3	15	65
G2	-	-	-	-	200	-	-	-	-	17	-

Portata olio consigliata da 60 a 180 (lt/min)
Suggested oil flow from 60 to 180 (lt/min)

(x2) = doppio motore
(x2) = double engine

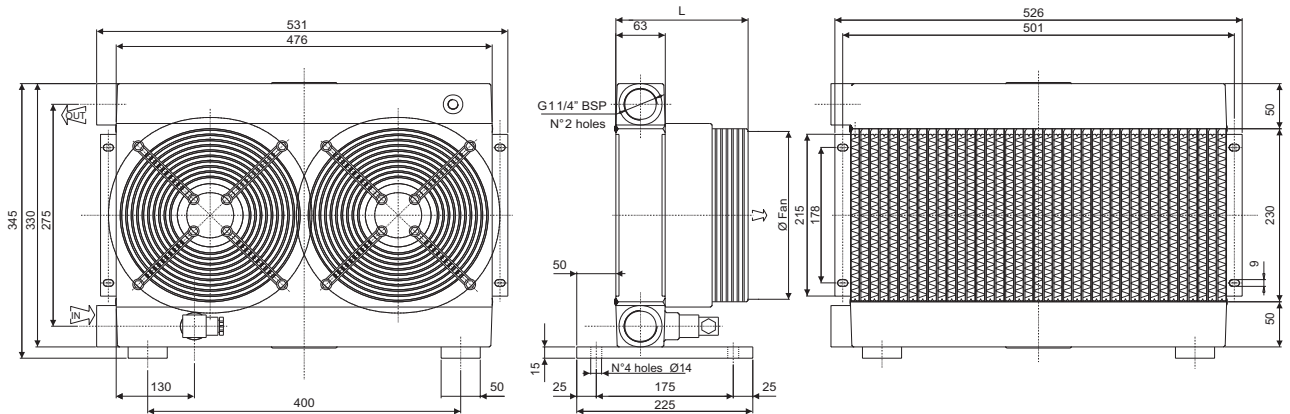

Coefficiente di correzione Correction factor

CST	10	15	20	32	40	50	60	80	100	200
F	0.51	0.66	0.76	1	1.22	1.4	1.6	1.9	2.1	3.4

Diagramma perdite di carico (32 cst) Pressure drop diagram (32 cst)



Diagramma di rendimento Performance diagram



Scambiatore tipo SD24 Serie Aria-Olio Heat exchanger series SD24 Air-Oil version

CARATTERISTICHE TECNICHE DEL GRUPPO DI VENTILAZIONE TECHNICAL FEATURES

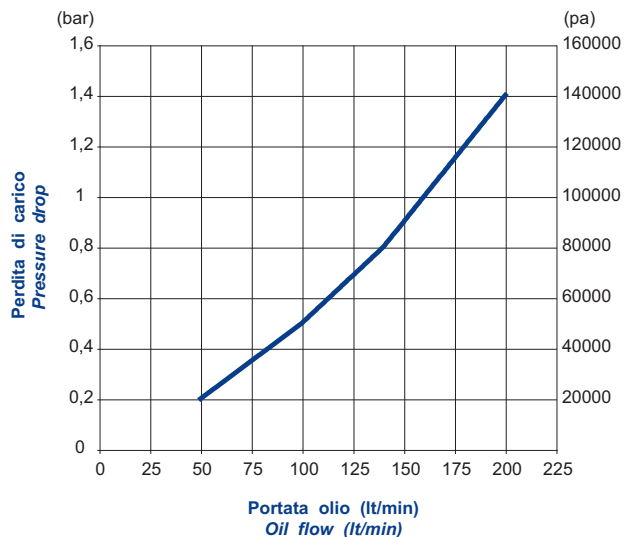
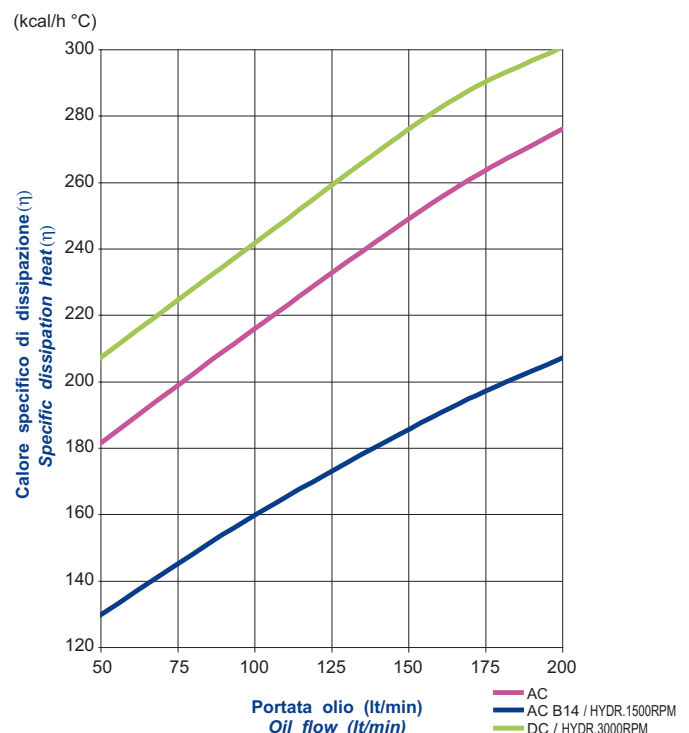
Tipologia Type	Frequenza Frequency Hz	Tensione Voltage V	N° Giri/min RPM	Potenza Power kW	Diam. Ventola Ø FAN (mm)	dB (A)	L (mm)	Q air (m³/h)	Cap. (lt)	Peso Weight (kg)	IP
01	50/60	230	2550/2750	0.11/0.16 (x2)	250	68	169	3560	1.9	23	44
03	50/60	400	2500/2650	0.10/0.14 (x2)	250	68	169	3560	1.9	23	44
14	50/60	230/400	1370	0.25 (x2)	250	68	364	3000	1.9	34	55
12	DC	12	3000	0.100 (x2)	280	66	176	3200	1.9	21	65
24	DC	24	3000	0.100 (x2)	280	66	176	3200	1.9	21	65
G2	-	-	-	-	250	-	-	-	-	23	-

Portata olio consigliata da 80 a 220 (lt/min)
Suggested oil flow from 80 to 220 (lt/min)

(x2) = doppio motore
(x2) = double engine

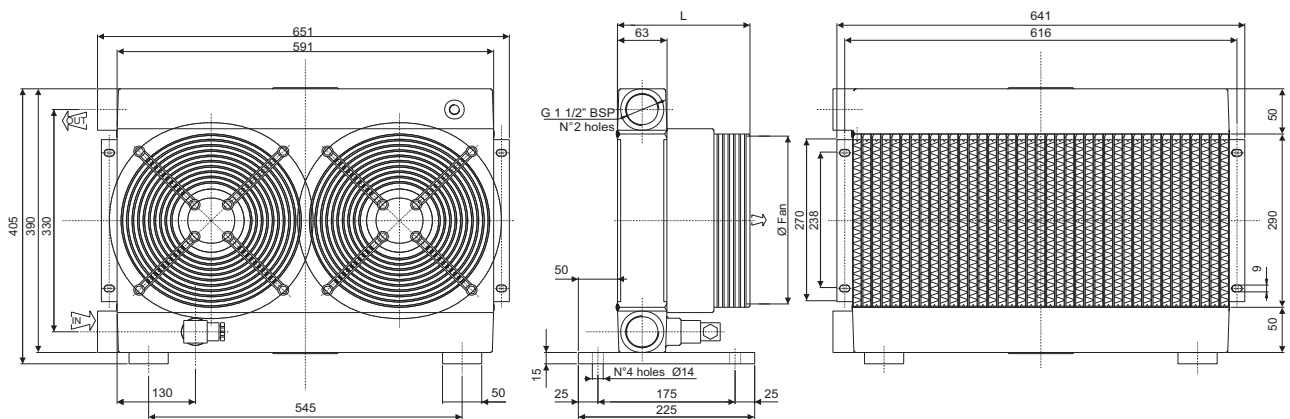

Coefficiente di correzione Correction factor

CST	10	15	20	32	40	50	60	80	100	200
F	0.51	0.66	0.76	1	1.22	1.4	1.6	1.9	2.1	3.4

Diagramma di rendimento Performance diagram



Diagramma perdite di carico (32 cst) Pressure drop diagram (32 cst)



Scambiatore tipo SD30 Serie Aria-Olio Heat exchanger series SD30 Air-Oil version

CARATTERISTICHE TECNICHE DEL GRUPPO DI VENTILAZIONE TECHNICAL FEATURES

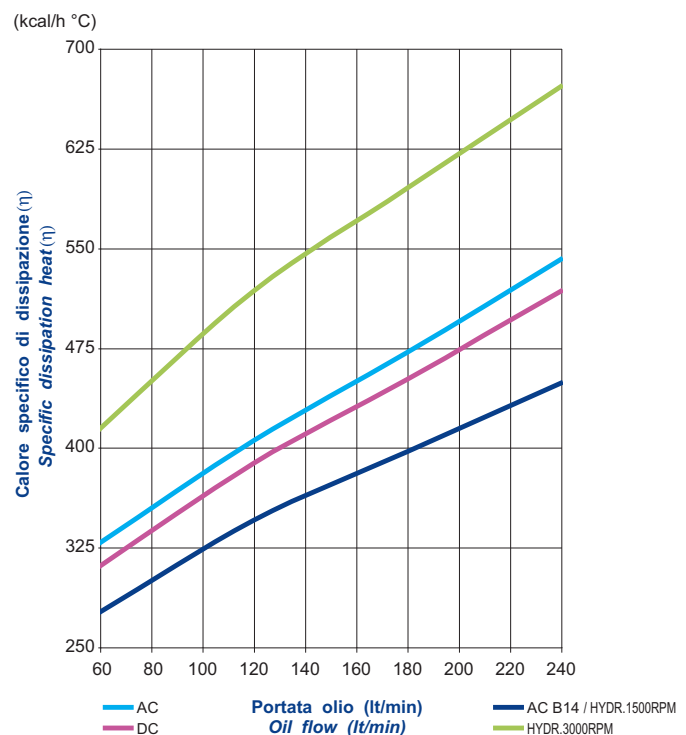
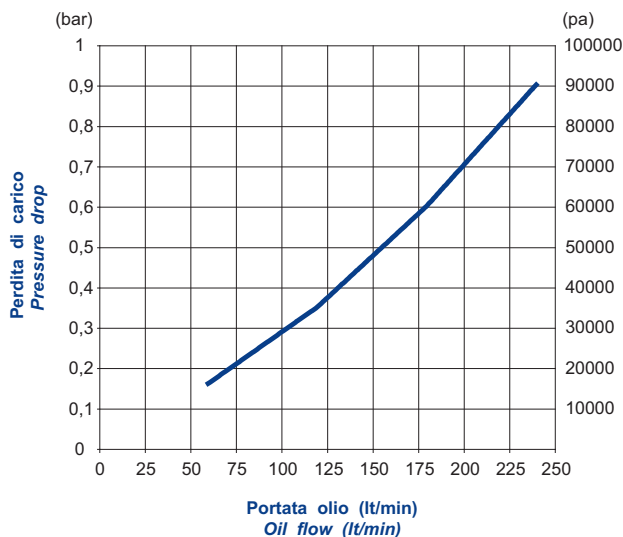
Tipologia Type	Frequenza Frequency Hz	Tensione Voltage V	N° Giri/min RPM	Potenza Power kW	Diam. Ventola Ø FAN (mm)	dB (A)	L (mm)	Q air (m³/h)	Cap. (lt)	Peso Weight (kg)	IP
01	50/60	230	2700/3000	0.23/0.35 (x2)	300	69	183	6580	3.1	31	44
03	50/60	400	2600/2850	0.19/0.27 (x2)	300	69	183	6580	3.1	31	44
14	50/60	230/400	1390	0.37 (x2)	300	69	404	4000	3.1	42	55
12	DC	12	3000	0.175 (x2)	305	67	219	4600	3.1	29	65
24	DC	24	3000	0.175 (x2)	305	67	219	4600	3.1	29	65
G2	-	-	-	-	300	-	238	-	3.1	30	-

Portata olio consigliata da 80 a 260 (lt/min)
Suggested oil flow from 80 to 260 (lt/min)

(x2) = doppio motore
(x2) = double engine

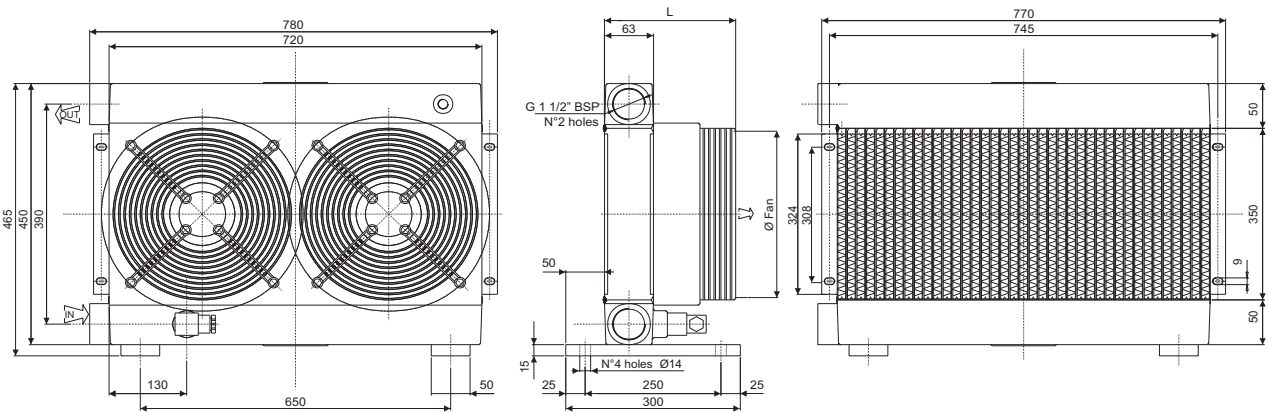

Coefficiente di correzione Correction factor

CST	10	15	20	32	40	50	60	80	100	200
F	0.51	0.66	0.76	1	1.22	1.4	1.6	1.9	2.1	3.4

Diagramma perdite di carico (32 cst) Pressure drop diagram (32 cst)



Diagramma di rendimento Performance diagram



Scambiatore tipo SD40 Serie Aria-Olio Heat exchanger series SD40 Air-Oil version

CARATTERISTICHE TECNICHE DEL GRUPPO DI VENTILAZIONE TECHNICAL FEATURES

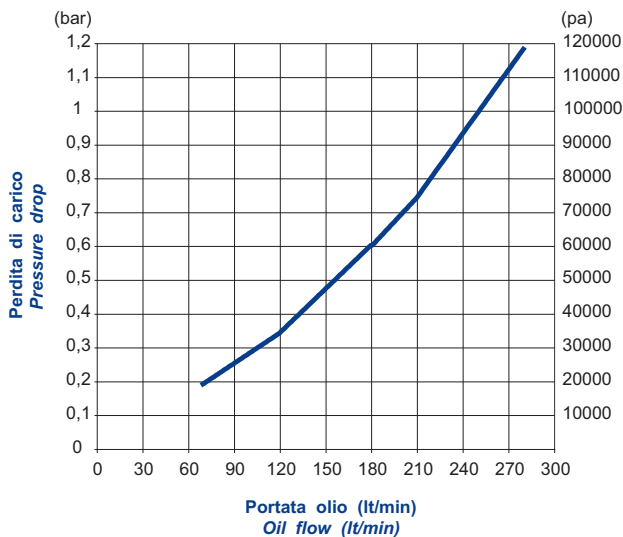
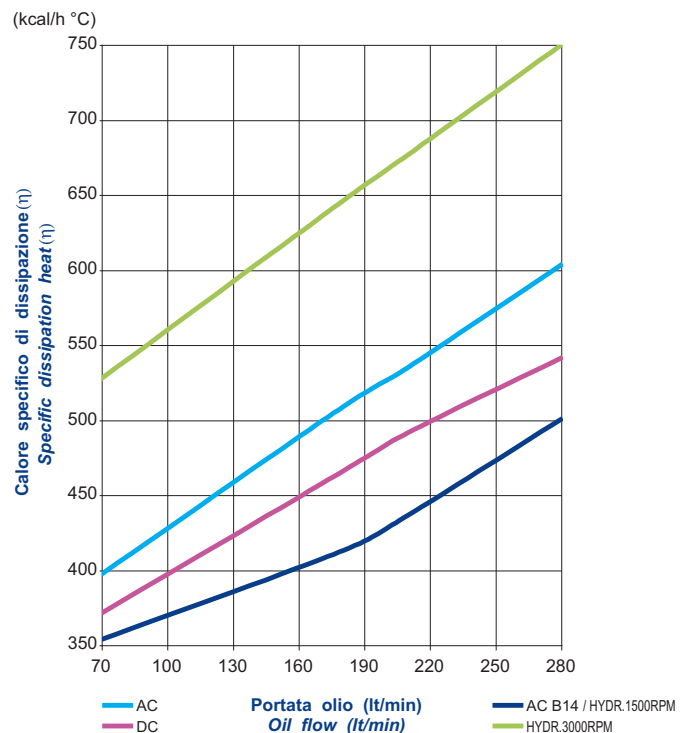
Tipologia Type	Frequenza Frequency Hz	Tensione Voltage V	N° Giri/min RPM	Potenza Power kW	Diam. Ventola Ø FAN (mm)	dB (A)	L (mm)	Q air (m³/h)	Cap. (lt)	Peso Weight (kg)	IP
01	50/60	230	1440/1700	0.16/0.24 (x2)	400	71	223	8000	5.3	42	44
03	50/60	400	1450/1690	0.13/0.18 (x2)	400	71	223	8000	5.3	42	44
14	50/60	230/400	1430	0.55 (x2)	400	71	446	8000	5.3	50	55
12	DC	12	2500	0.200 (x2)	385	69	229	7000	5.3	41	65
24	DC	24	2500	0.200 (x2)	385	71	229	7000	5.3	41	65
G2	-	-	-	-	400	-	248	-	5.3	39	-

Portata olio consigliata da 80 a 300 (lt/min)
Suggested oil flow from 80 to 300 (lt/min)

(x2) = doppio motore
(x2) = double engine

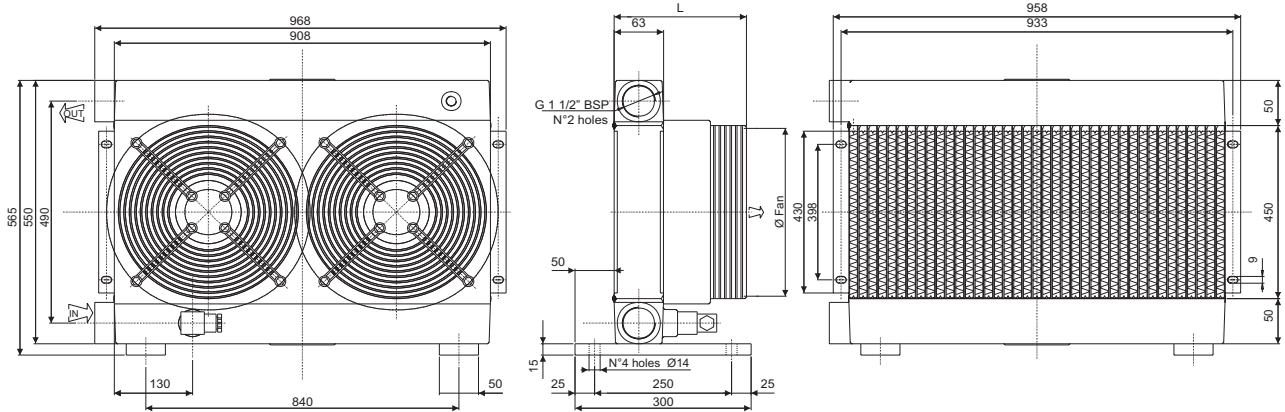

Coefficiente di correzione Correction factor

CST	10	15	20	32	40	50	60	80	100	200
F	0.51	0.66	0.76	1	1.22	1.4	1.6	1.9	2.1	3.4

Diagramma di rendimento Performance diagram



Diagramma perdite di carico (32 cst) Pressure drop diagram (32 cst)



ACCESSORI ACCESSORIES

TERMOSTATO BIMETALLICO FISSO / BIMETALLIC FIXED TEMPERATURE SWITCH

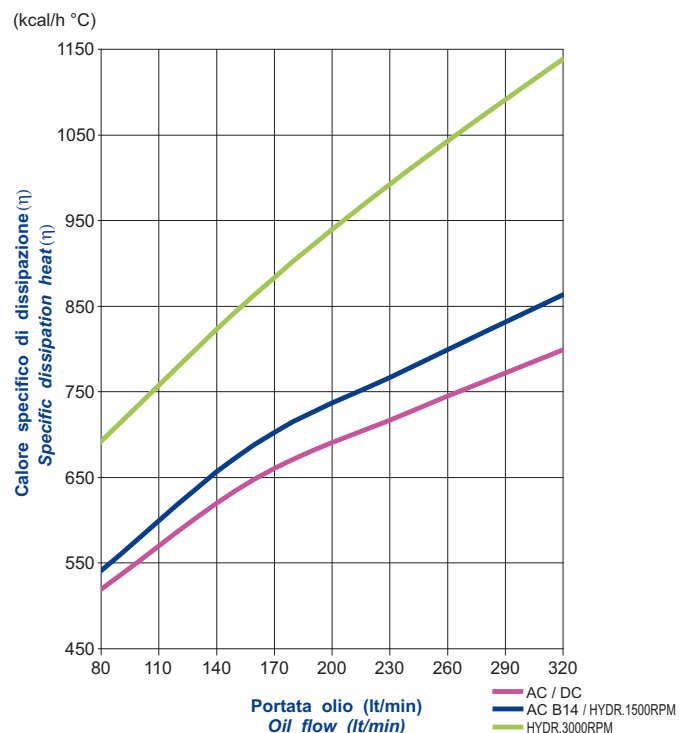
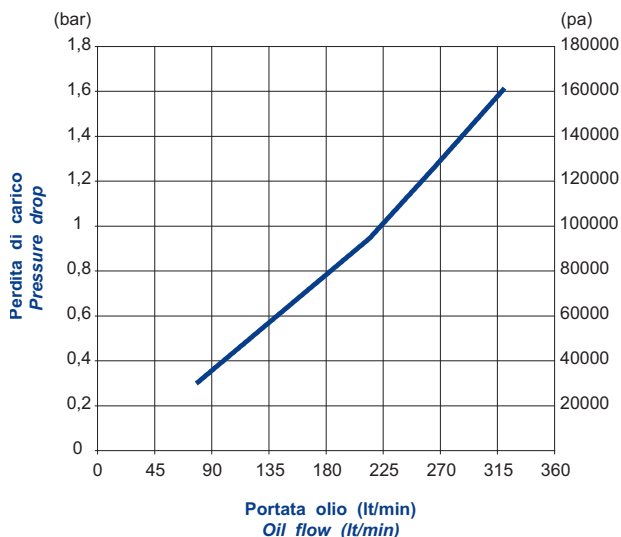
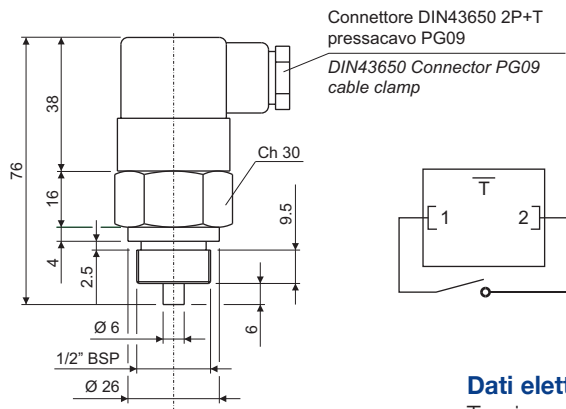

N.B.: Assemblare il termostato allo scambiatore con una rondella piana in rame.

Codice termostato Switch part number	Temperatura d'intervento Working temperature	Contatto Contact
T01	36-26°C	
T02	43-33°C	
T03	52-42°C	
T04	65-55°C	NA/NO
T05	75-65°C	
T06	85-75°C	
T07	95-85°C	

NA = normalmente aperto
NO = normally open

Dati elettrici / Electrical data

Tensione max. / Max. voltage	250Vca
Corrente max. / Max. current	10A
Tolleranza intervento / Tolerance	±5°C
Differenziale fisso max. / Max. fixed hysteresis	15°C
Connessione elettrica / Electrical connection	DIN43650
Protezione elettrica / Protection degree	IP65
Temperatura max. / Max. temperature	130°C

Materiali / Materials

Corpo / Body	Ottone / Brass
Contatti / Contacts	Argentati / Silver plated

TERMOSTATO REGOLABILE / TEMPERATURE SWITCH

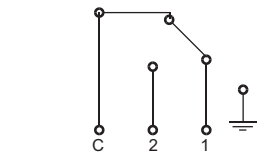
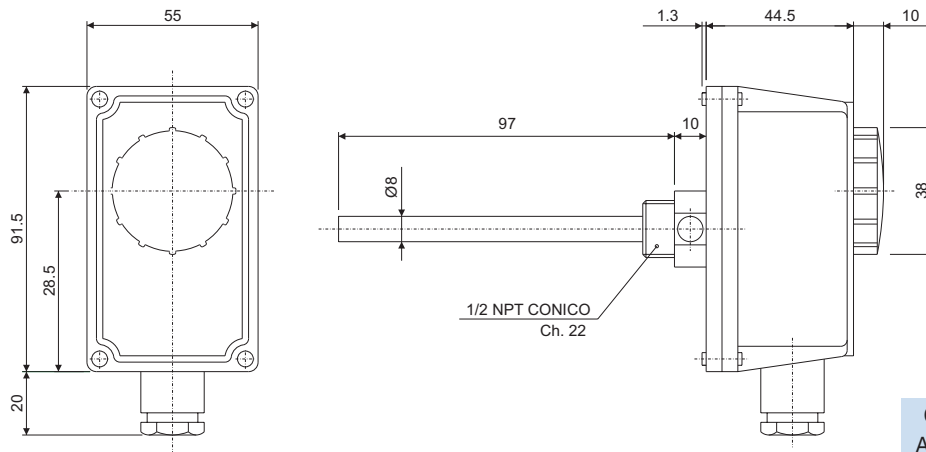

Morsetto 1: apre il circuito all'aumentare della temperatura
Morsetto 2: chiude il circuito all'aumentare della temperatura
Comune: entrata comune

Codice termostato regolabile
Adjustable switch part number

T08

Dati elettrici / Electrical data

Campo di regolaz. temp. / Temperature range	0°±90°C
Tolleranza / Tolerance	±5k
Differenziale / Temperature differential	6±2k
Grado di protezione / Degree of protection	IP 40
Classe di isolamento / Insulation class	I
Gradiente termico / Temp. rate of change	<1k/min
Temperatura max. testa / Max. head temperature	80°C
Temperatura max. bulbo / Max. sensing bulb temp.	125°C
Temperatura di stoccaggio / Storage temperature	-15°C 55°C
Costante di tempo / Time constant	<1'
Portata sui contatti / Contacts rating	C-1:10(2.5)A/250V~ C-2:6(2.5)A/250V~
Uscita / Output	contatti in interruzione o in commutazione cutoff or switching contacts
Tipo di azione / Switch action	1B
Situazione di installaz. / Installation location	ambiente normale / normal environment
Passacavo / Fairlead type	M20x1.5

Codice di ordinazione Aria-Olio serie S

How to order Air-Oil series S

SS20

Tipologia di scambiatore Type
SS10
SS15
SS20
SS24
SS30
SS40
SS50
SS215 (2pass)
SS220 (2pass)
SS224 (2pass)
SS230 (2pass)
SS240 (2pass)
SD20
SD24
SD30
SD40

14

Termostati bimetallici fissi Bimetallic fixed temperature switches	
00	Senza termostato No switch
01	Termostato fisso 36-26 °C Fixed switch 36-26 °C
02	Termostato fisso 43-33 °C Fixed switch 43-33 °C
03	Termostato fisso 52-42 °C Fixed switch 52-42 °C
04	Termostato fisso 65-55 °C Fixed switch 65-55 °C
05	Termostato fisso 75-65 °C Fixed switch 75-65 °C
06	Termostato fisso 85-75 °C Fixed switch 85-75 °C
07	Termostato fisso 95-85 °C Fixed switch 95-85 °C

02

Termostato regolabile Adjustable switch	
08	Termostato regolabile 0-90 °C Adjustable switch 0-90 °C

A

- P

Staffe / Cablaggio Foot flanges / Electric connection	
P	Con staffe di fissaggio With foot flanges
E	Con cablaggio elettrico With electric connection
PE	Con staffe di fissaggio e con cablaggio elettrico and with electric connection

P - PE
valida solo per / applicable only for
SS10; SS15; SS20; SS24; SS30;
SS40; SS215; SS220; SS224;
SS230; SS240.

E
valida solo per / applicable only for
SS50; SD20; SD30; SD40.

Tipi di ventilazione Fans	
A	Aspirante Drawing

Tipi di ventilazione Fan Motor

01	230V 50/60 Hz monofase 230V 50/60 Hz single phase
03	400V 50/60 Hz trifase *** 400V 50/60 Hz three phase ***
14	230/400V 50/60 Hz trifase B14 230/400V 50/60 Hz three phase B14
12	12V CC
24	24V CC
⌚	Predisposto per motore idraulico GR.2 Arranged for hydraulic motor GR.2

*** SS50 230/400V 50/60 Hz trifase - Three phase

APPLICAZIONI SPECIALI

Per tutte le applicazioni che non rientrano nei casi normali specificati in questo catalogo contattare l'ufficio commerciale della OMT per un eventuale studio di fattibilità.

SPECIAL APPLICATIONS

For special solutions or particular applications, please contact OMT commercial department for informations.

SCAMBIATORI
HEAT EXCHANGERS

FILTRI
FILTERS

ACCESSORI
ACCESSORIES

COMPONENTI
COMPONENTS

FLANGE / FLANGES
RACCORDI / COUPLINGS
BLOCCHI / MANIFOLDS

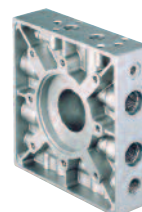

Scambiatori - Exchangers