

Descriptio

or starting, controlling and stopping the working fluid between the generator of pressure flow, the consumers and the Tank. Предназначение для изменения направления потока, ограничения давления рабочей жидкости в гидролинии, разгрузка насоса в нейтральной позиции золотника.

Specifications

Основные показатели

1. Valve monoblo	оноблок
2. Mounting	2 bolts M8
Крепление	
3.Ports	internal thread
Присоединительные отверстия	резбовые отверстия
4.Ambient temperature	-40 – +60 C
температура воздуха	
5.Pressure medium	mineral oil
Рабочая жидкость	
6.Viscosity	12...800 mm/s
Вязкость	20...100 mm/s
	recommended range
7.Fluid temperature	-30 – +80 C
8.Filtration	oil contaminations
	class 10 to NAS 1683
	achived with filter 75
9.Max. operating pressure	P = 250 bar
	A, B = 300 bar
	T < 50 bar
10 Internal leakage	5 ccm/min at 100 bar
	viscosity 46 mm/s
11.Nominal flow	40 l/min (operating diagram)
12.Spool stroke	+– 6 mm
13.Actuating force	< 200 N in spool axis

Left hand configuration – standard

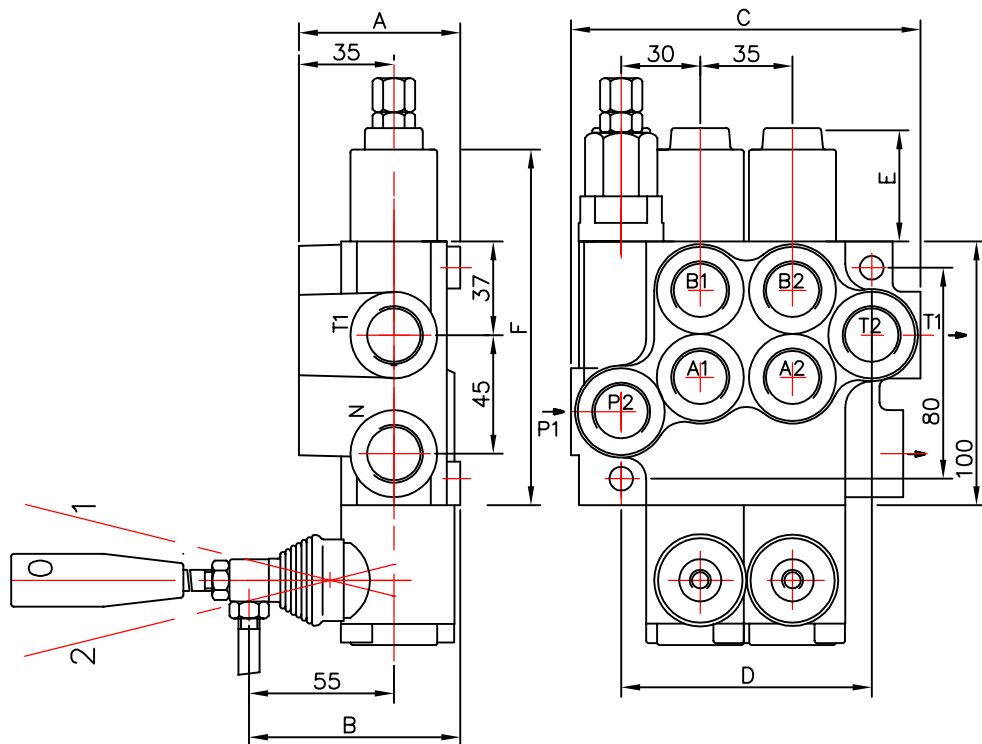

Right hand configuration

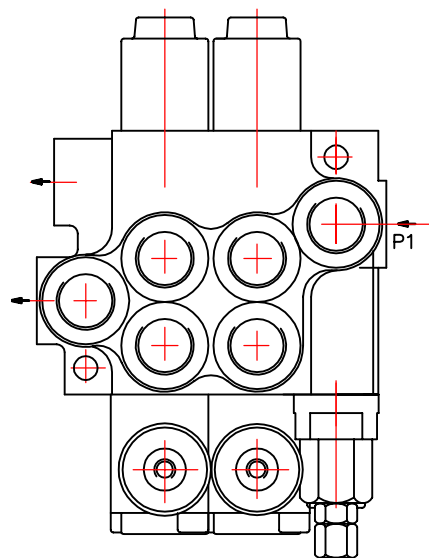

Table 1

	A	B	C	D	P1	P2	T1	T2
01Z50	60	80	85	60	+	-	+	-
02Z50	60	80	129	97	+	+	+	+
03Z50	60	80	164	132	+	+	+	+
04Z50	60	80	199	167	+	+	+	+
05Z50	60	80	234	202	+	+	+	+
06Z50	60	80	269	237	+	+	+	+
07Z50	60	80	304	272	+	+	+	+

Table 2

spool control фиксация золотника	E	F
1; 4; 5; 6; 7; 8; 9; 10; 11;	40	193
2; 3;	72	225
16	+	+

Table 3

code	spools
01	1
02	2
03	3

ets.

- 0** block with common check valve
 распределитель с общим клапаном
2 number of spools
 количество золотников
Z50 directional control valve type ...
 распределитель типа ...
R inlet high pressure – right
 вход давления с правой стороны
A 1 first spool distribution type
 характеристика первого золотника
A 1 spool control/detend and ets./
 контрол золотника/фиксация и грузе/
A 1 second spool distribution type
 вид второго золотника
1 spool control/detend and estr./
 контрол золотника/фиксация и грузе/
G ports/treads/
 резьбовые отверстия
KZ1 general operation feature
 вид ручного управления
T with "teton"
 исполнение ручного управления с "тетон"
H operation feature /pneumatic, .../
 грузе управление
E with electric switch
 с электрическим выключателем
C2 high pressure carry over
 продолжител потока высокого давления
11 connection ports in use
 присоединительные отверстия

directional control valve Z50

Table 4

code	way of distribution ; распределение потока
1	parallel ; параллельное

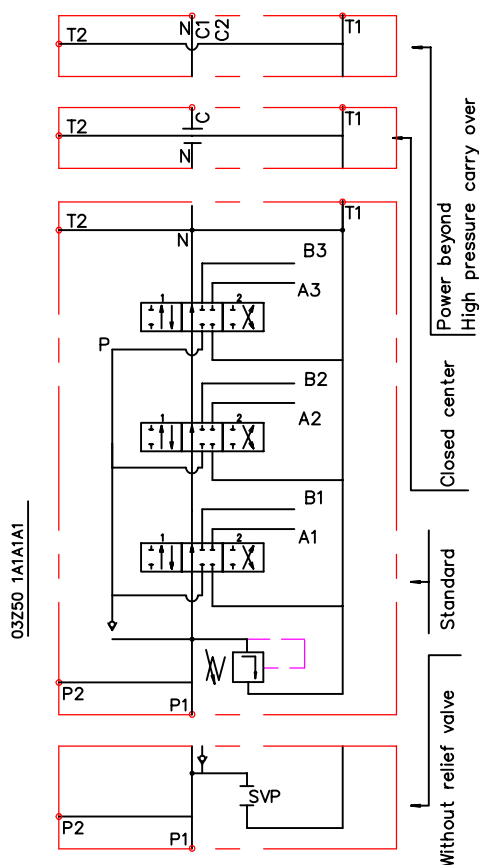
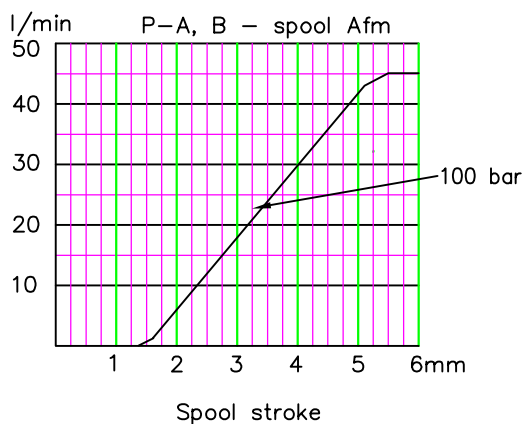

Table 5

code	spool type
A	
B	
C	
D	
E	
F	
G	
H	
M	
N	
O	
P	
Q	
R	
S	
T	
K	
L	

Table 6

code	spool control
1	
2	
3	
4	
5	
6	
7	
8	
9	
10	
11	
* 15	
* 16	
** 12	
** 13	



* только при вход слева (дуг) only for left hand configuration
 ** только при вход справа (дуг) only for right hand configuration
 *** Spool Afm – fine metering

Table 7

code	с микро шалтер ; incorporated microswitch
E	 mikroswitch type Omron-V 165 I C5

Table 8

code	другое управление ; operation feature
P	 пневматическое on-off pneumatic control; 5–10 bar ; ports NPTF 1/8–27
H	 гидравлическое on-off hydraulic control ; pn = 5 – 20 bar ; ports G1/4

directional control valve Z50

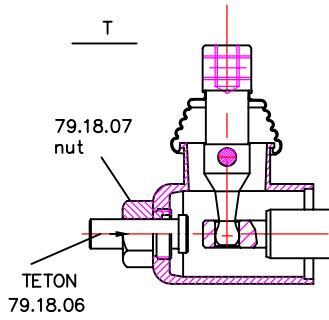

Z50

Table 9

code	ports (treads) ; присоединительные отверстия				
	P	A ; B	T	N	C2
M	M22x1.5	M18x1.5	M22x1.5	M22x1.5	M22x1.5
G	G1/2	G3/8	G1/2	G1/2	G1/2
S	7/8-14UNF	3/4-16UNF	7/8-14UNF	7/8-14UNF	7/8-14UNF

kind of hand control ; вид ручного управления

Table 10

code	ескуз feature	code	ескуз feature	code	ескуз feature
KZ		KY		KI	
KZ1		KY1		KI1	
KZO		KYO		KIO	
KZ01		KY01		KI01	
-	without hand control ; без ричажная система управления				

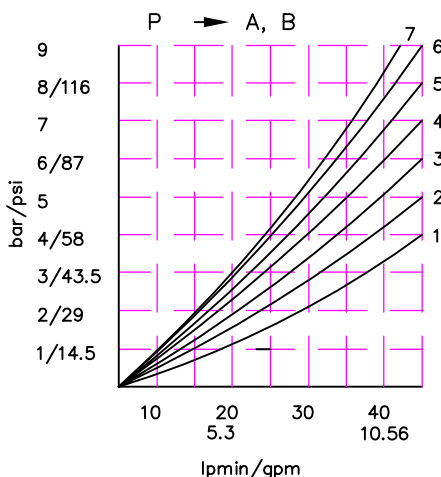
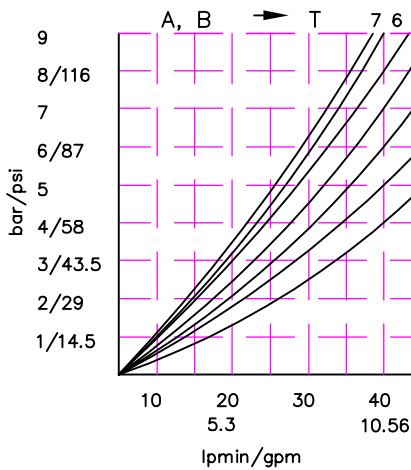
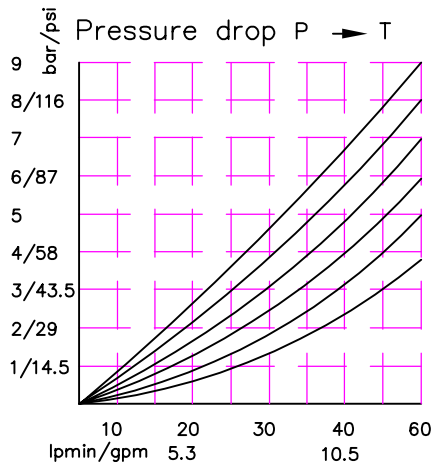

Table 11

code	вид прогължение на дебита	
C	отбор "N" затворен closed center	
C2	отбор "N" прогължава за следващ консуматор part for power beyond sleeve(carry over)	
-	отбор "N" е свързан с "T" without part for pressure carry over	
X	отбор "N" е винаги свързан с "T" power beyond ever to tank	

Table 12

code	used connection ports ; присоединительные отверстия
11	P1 ; T1
12	P1 ; T2
21	P2 ; T1
22	P2 ; T2

REMOTE CONTROLS

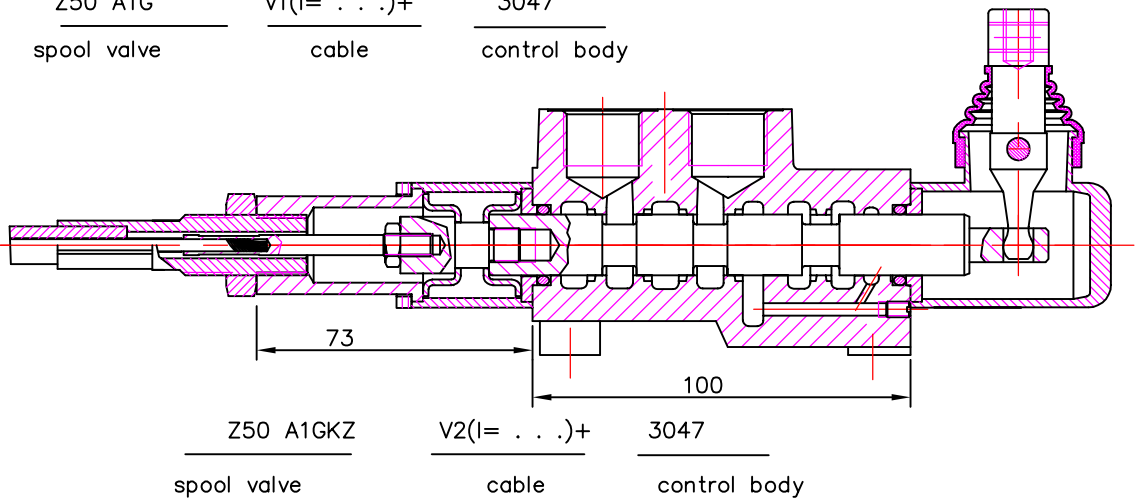
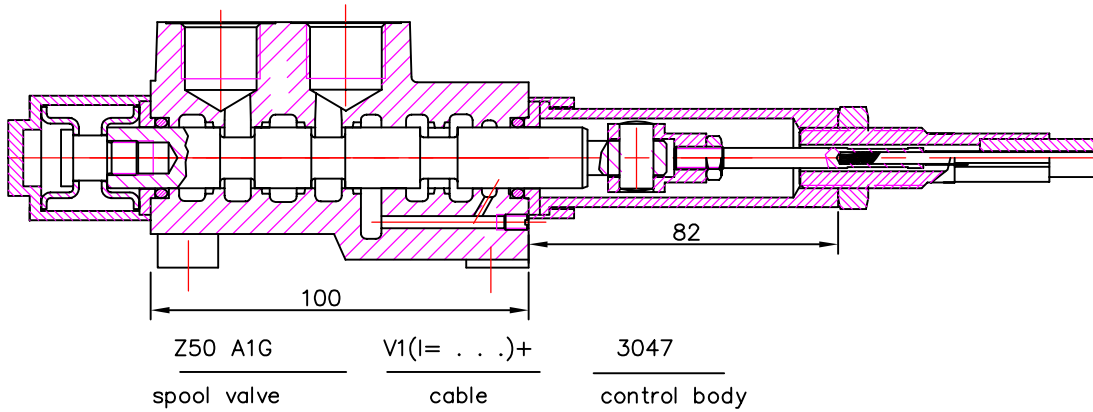

Cable "INDEMAR" Cod. IT 3056 /l=1.00; 1.50; 2.00; 2.50; 3.00 m/
 +control body "INDEMAR" code 3047, 3076, 3077

Technical specifications			
	3047	3076	3077
Stroke	13+13 mm	13+13 mm	13+13 mm
Max. load	45 kg	45 kg	45 kg
Level ratio	10:1	10:1	10:1
Lock in neutral	No	No	Yes
Antireverse lock	No	Yes	No
Body colour	Black	Black	Black
Cables type	Heavy Duty	Heavy Duty	Heavy Duty
Operating temperature	-40/+80C	-40/+80C	-40/+80C

High solidity controls for easy mounting on every type of distributor. They can be mounted stand alone or packed together. They use push-pull heavy duty cables that provide a positive smooth operating lever and are manufactured in a three different models to meet different needs of CI'

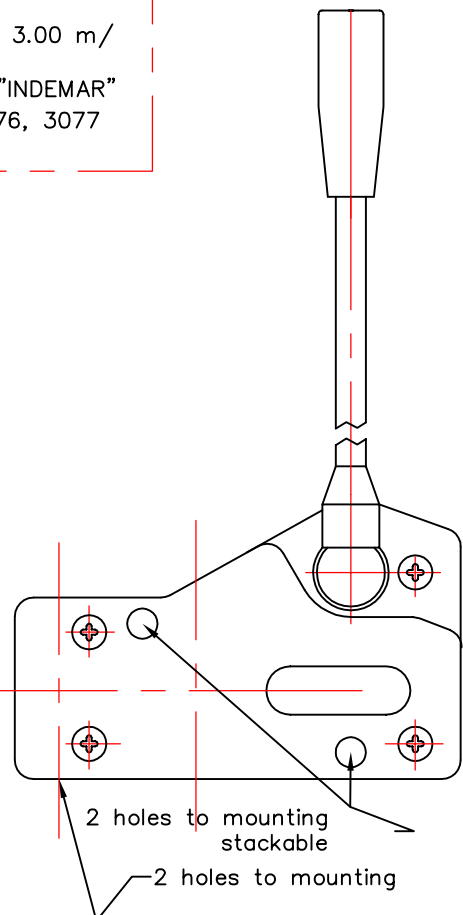

JOYSTICK "+"

This control gives the possibility to operate, at the same time two spools with a "+" movement.

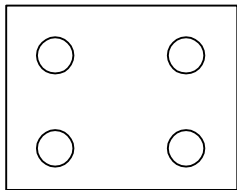
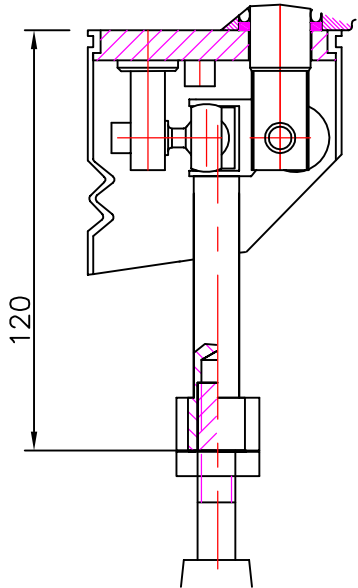

standard version 1

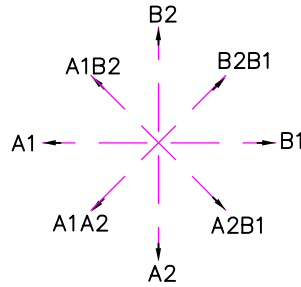
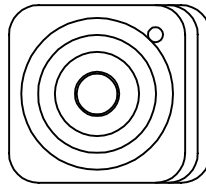

standard version 2

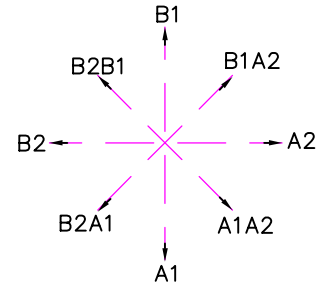
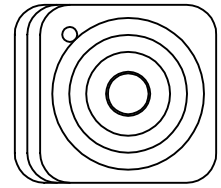

standard version 3

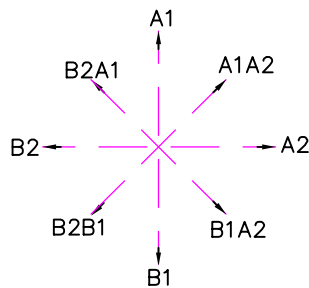
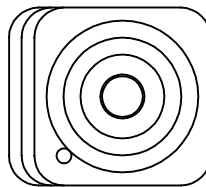

standard version 4

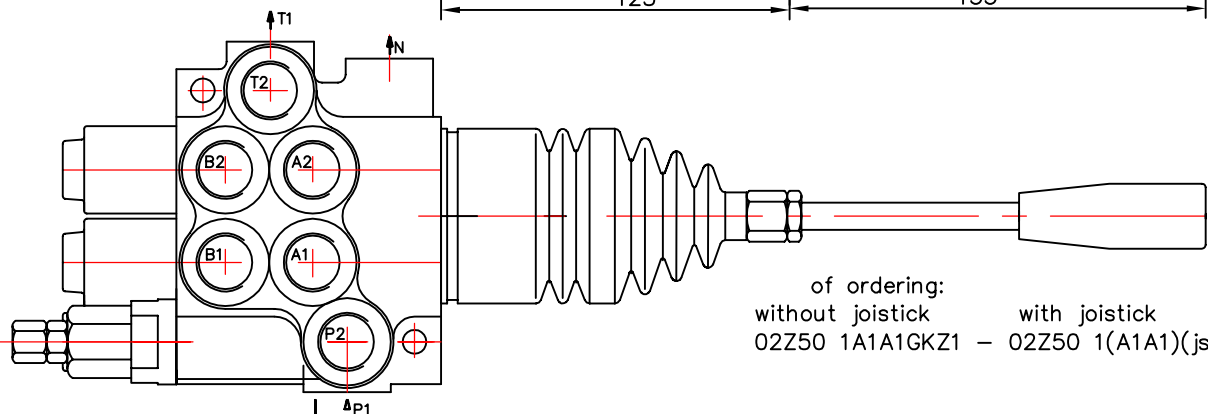
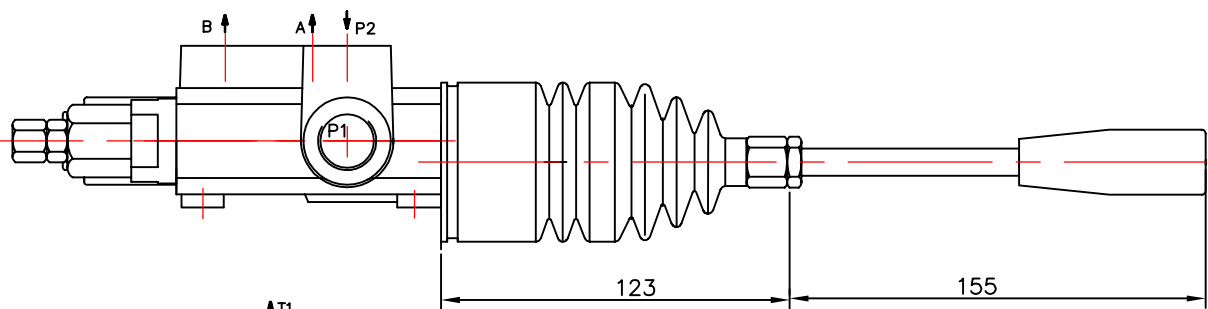
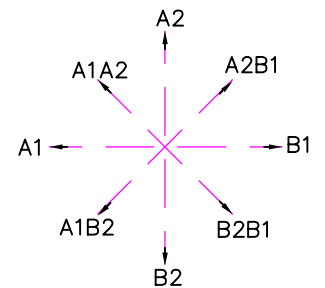
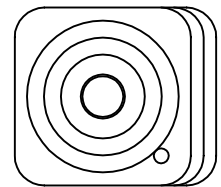

of ordering:
 without joystick: 02Z50 1A1A1GKZ1 - with joystick: 02Z50 1(A1A1)(js+3)G

ED3 – electro-hydraulic control ON-OFF
 Электрогидравлический контрол ON-OFF

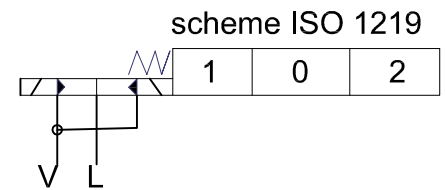
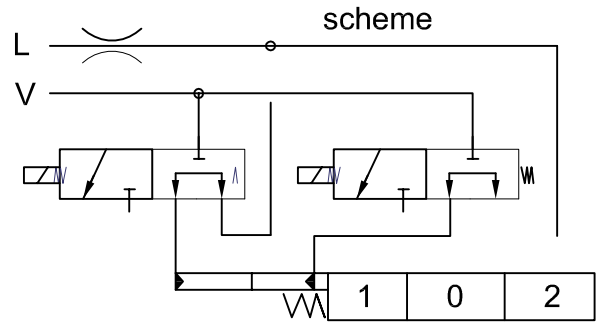
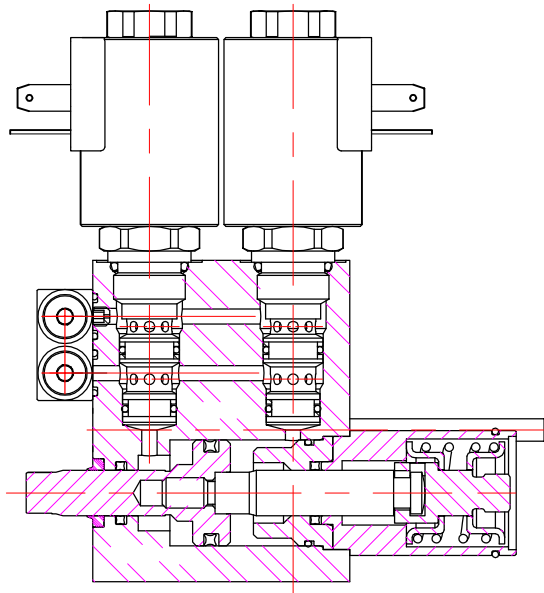

Operating pressure min 10 bar(145 psi)
 max 50 bar(725 psi)
 Max operating pressure in L (T line) 25 bar(360 psi)

Ordering codes
 3-way solenoid valve-SV08-33
 coil P40ED3-G-12VDC
 coil P40ED3-G-24VDC

Solenoid operating features
 Nominal voltage tolerance ±10%
 Power rating 24W
 Duty cycle 100 %

Collector kit for external pilot and drain – CEED

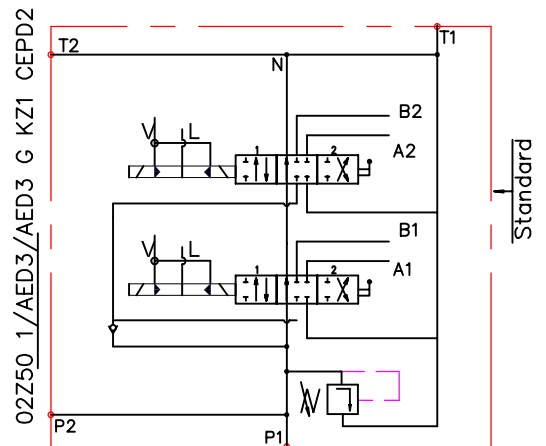
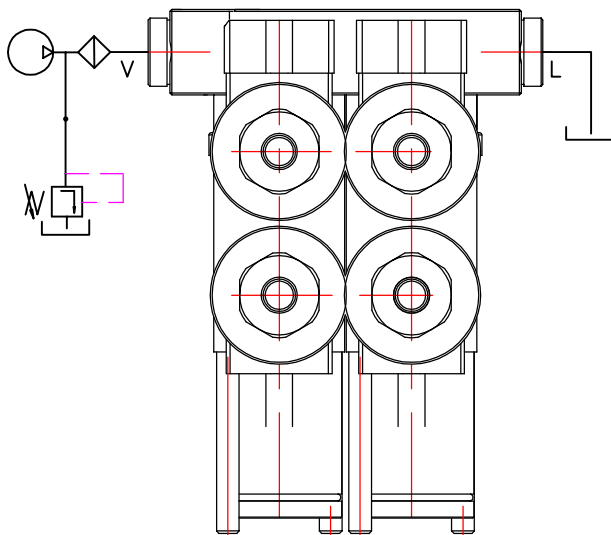

Ordering example

02Z50-1/A1ED3/A1ED3 G KZ1-CEED2-12VDC

Ordering codes (BSP threads)

CEED1P40	Kit for 1 section
CEED2P40	Kit for 2 section
CEED3P40	Kit for 3 section
CEED4P40	Kit for 4 sektion
.....	

directional control valve Z50

ED3 – electro-hydraulic control ON-OFF
 Электрогидравлический контрол ON-OFF

Order codes
 3-way solenoid valve-LSV2-08-3C
 coil P40ED3-G-12VDC
 coil P40ED3-G-24VDC

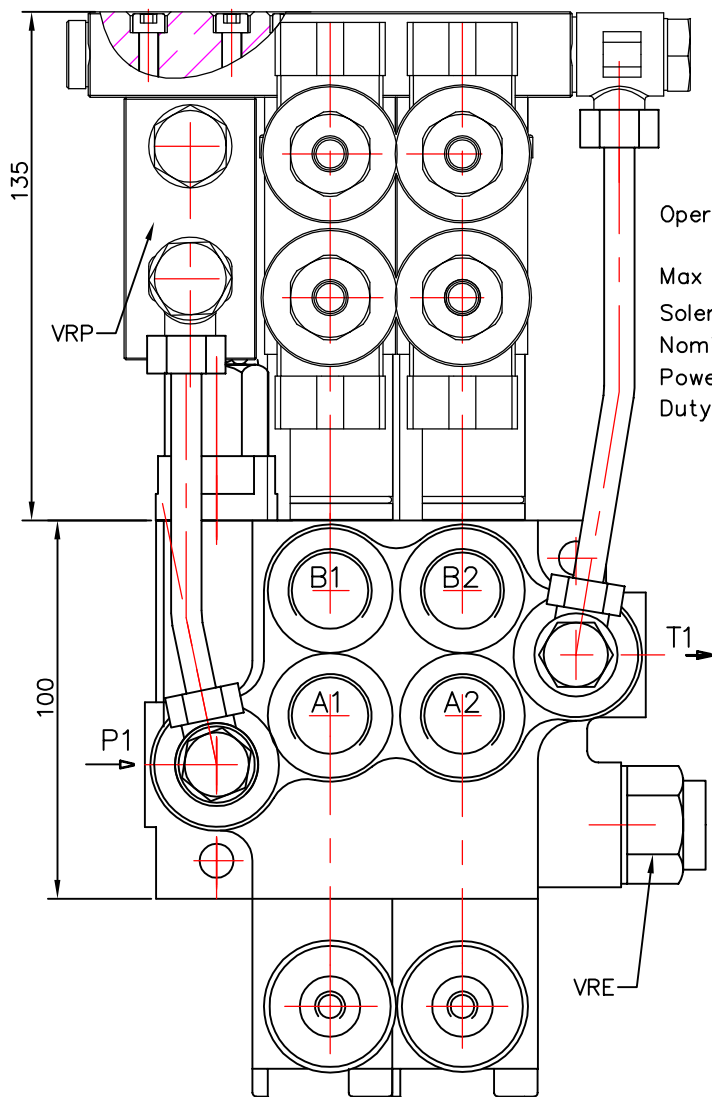

Operating pressure min 10 bar(145 psi)
 max 50 bar(725 psi)
 Max operating pressure in L (T line) 25 bar(360 psi)
 Solenoid operating features
 Nominal voltage tolerance ±10%
 Power rating 24W
 Duty cycle 100 %

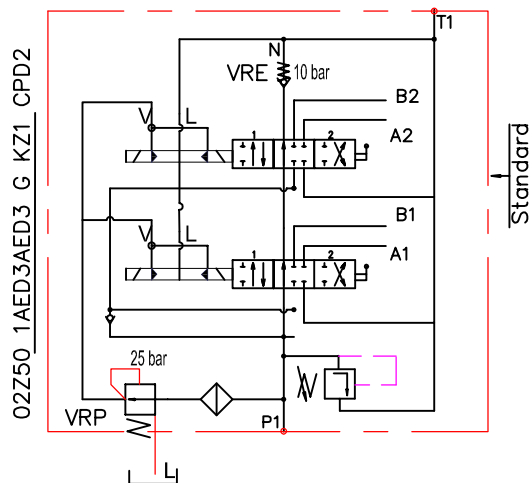

Ordering example

02Z50-VRP- 1/A1ED3/A1ED3 G KZ1-CED2-VRE-12VDC

Collector kit - BSP threads
 Ordering codes

CED1 Kit for 1 section
 CED2 Kit for 2 section
 CED3 Kit for 3 section
 CED4 Kit for 4 sektion

Back pressure valve VRE-P40

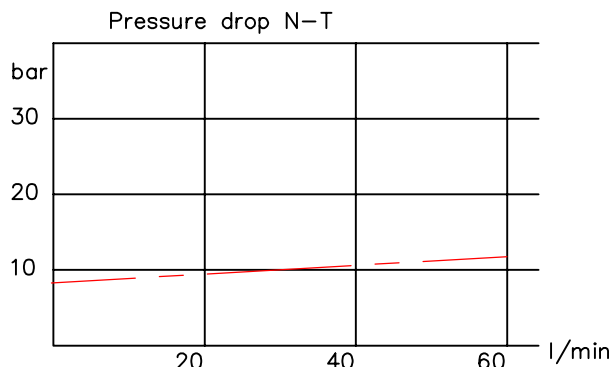
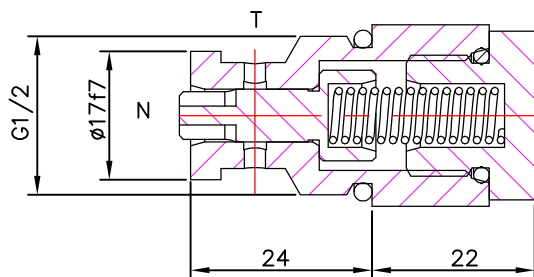

directional control valve Z50
 ES ... SOLENOID DIRECT CONTROL

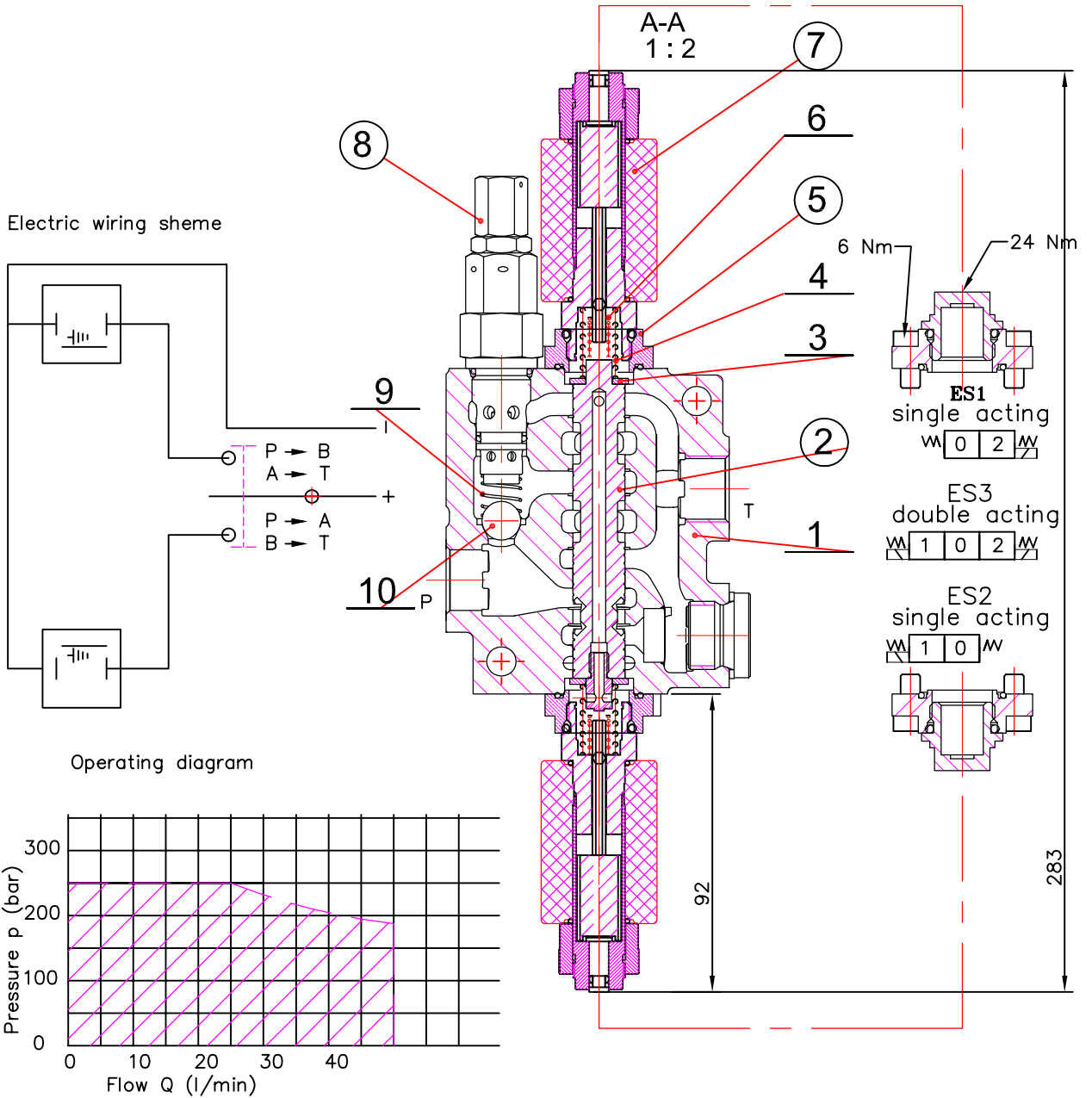

Operating features

Control
 Internal leakage A(B) → T
 (p=120 bar, Viscosity=32 mm²/s : max 30 ccm/min)
 Fluid temperature – -20°C(short time) ... 80°C
 Max. back pressure on outlet port T – 25 bar(360 psi)

Coil
 Nominal voltage tolerance ±10%
 Power rating 37 W
 Coil insulation class H
 Duty cycle 100%
 Connector ISO 4400
 lmergency manual override

pos.	Part.No	Description	Quantity
10		Ball 12	1
9	79.00.03	Spring	1
8	79.04.00	Relief valve	1
7b	C35D012RC P01	Solenoid coil	2
7a	GM4060/BD	Solenoid Tube	2
6	542.02.00.07	Additional spring	2
5	542.02.03.00	Intermediate unit	2
4	542.02.00.04	Spring	2
3	542.02.00.02	Washer	2
2		Spool ...	1
1		Body ...	1

directional control valve Z50

ES ... SOLENOID DIRECT CONTROL

Solenoid direct control with spring return to neutral position.
Needs special spools and special body Z50.

ORDERING EXAMPLE

Z50	A	ES3	12VDC	G
1	2	3	4	5

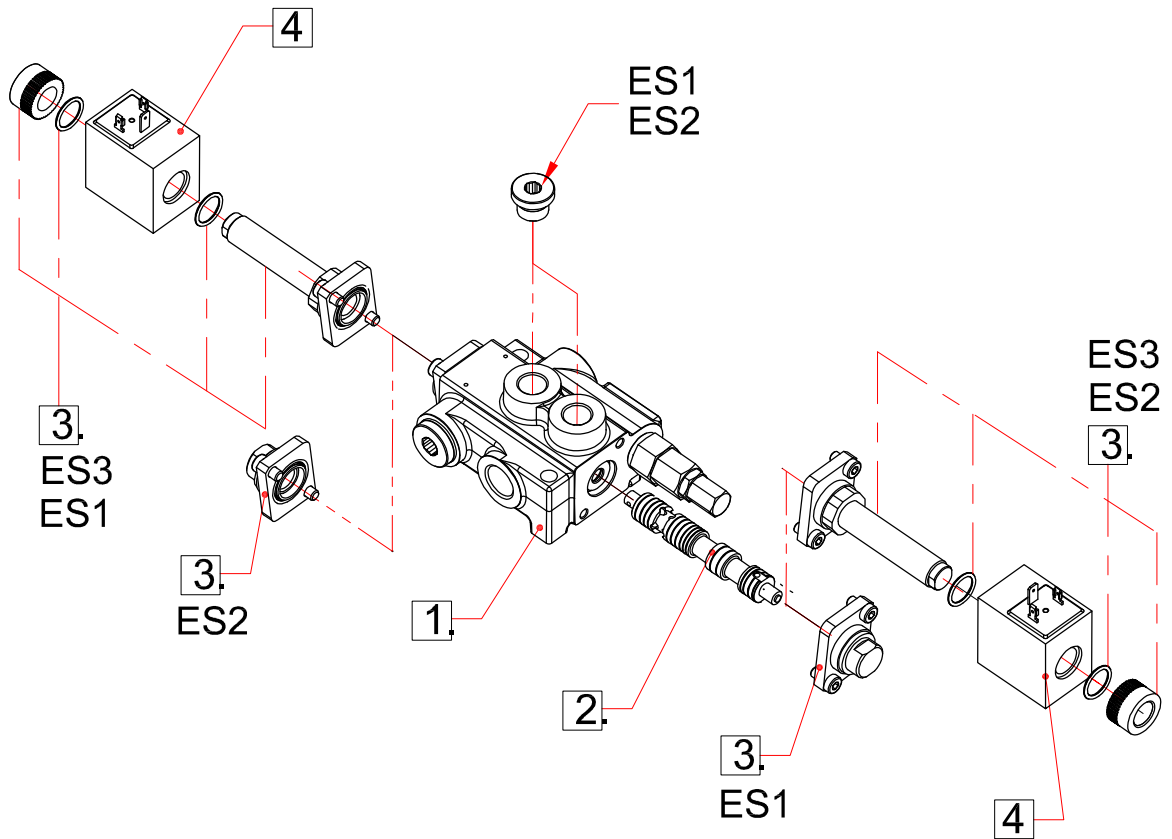

1.Body kit

Type	Description
Z50	1 spool
02Z50	2 spool
03Z50	3 spool
04Z50	4 spool
05Z50	5 spool
06Z50	6 spool

2.Spool options

Type	Description
A	Double acting, 3 positions with A and B closed in neutral position
D	Double acting, 3 positions with A and B open to Tank in neutral position

3.Control kit

Type	Description
ES1	Single acting P – A with spring return in neutral position
ES2	Single acting P – B with spring return in neutral position
ES3	Double acting P – A (B) with spring return in neutral position

4.Coils

Type	Description
(with connector ISO 4400)	
12VDC	Nominal voltage 12VDC
24VDC	Nominal voltage 24VDC

5.Threads

G	P, T – G1/2; A, B – G3/8
---	--------------------------