

ORDER CODE / SİPARİŞ KODU



1	2	3	4	5	6	7	8	9	0	1
M	R									

Pos.1 - Mounting Flange / Montaj Bağlantısı

omit - Oval mount , two holes
ihmal - Oval, iki delikli

- | | |
|---|---|
| F | - Oval mount, four holes / Oval, dört delikli |
| Q | - Square mount, four bolts / Kare, 4 civatalı |
| W | - Wheel mount / Tekerlek şekilli |

Pos.2 - Option (needle bearings) / Seçenekler

omit - none
ihmal - hiç birşey

- | | |
|---|--|
| N | - with needle bearings / yataklama yapılarak |
|---|--|

Pos.3 - Port type / Port tipi

omit - Side ports
ihmal - Yan portlar

- | | |
|---|-----------------------------|
| E | - Rear ports - Arka portlar |
|---|-----------------------------|

Pos.4 - Displacement code / Hacim kodları

- | | |
|-----|------------------------------|
| 50 | - 51,5 cm ³ /rev |
| 80 | - 80,3 cm ³ /rev |
| 100 | - 99,8 cm ³ /rev |
| 125 | - 125,7 cm ³ /rev |
| 160 | - 159,6 cm ³ /rev |
| 200 | - 199,8 cm ³ /rev |
| 250 | - 250,1 cm ³ /rev |
| 315 | - 315,7 cm ³ /rev |
| 400 | - 397,0 cm ³ /rev |

Pos.5 - Shaft Extensions* / Şaft Ölçüleri

- | | |
|-----|---|
| C | - ø25 straight, Parallelkey A8x7x32 DIN6885 / düz paralel anahtarlı |
| VC | - ø25 straight, Parallelkey A8x7x32 DIN6885 / düz paralel anahtarlı
with corrosion resistant bushing / korozyona karşı dayanıklı yatak |
| CO | - ø1" straight, Parallelkey ¼"x¼"x1¼" BS46 / düz paralel anahtarlı |
| VCO | - ø1" straight, Parallelkey ¼"x¼"x1¼" BS46 / düz paralel anahtarlı
with corrosion resistant bushing / korozyona karşı dayanıklı yatak |
| SH | - ø25,32 splined Bs2059 (SAE6B) / Frezelenmiş |
| VSH | - ø25,32 splined BS2059 (SAE6B) / Frezelenmiş
with corrosion resistant bushing / korozyona karşı dayanıklı yatak |
| K | - ø28,56 tapered 1:10, Parallelkey B5x5x14 DIN6885 / Paralel anahtarlı |
| SA | - ø24,5 splined B25x22 DIN5482 / Frezelenmiş |
| VSA | - ø24,5 splined B25x22 DIN5482 / Frezelenmiş
with corrosion resistant bushing / Korozyona karşı dayanıklı |

- | | |
|----|--|
| CB | - ø32 straight, Parallelkey A10x8x45 DIN6885
- Düz Paralel anahtarlı |
| KB | - ø35 tapered 1:10, Parallelkey B6x6x20 DIN6885
- Konik geçmiş Paralel anahtarlı |
| SB | - splined A25x22 DIN5482 / Frezelenmiş |
| OB | - ø1¼" tapered 1:8, Parallelkey 5/16"x5/16"x1¼" Bs46
- Konik geçmiş Paralel anahtarlı |
| HB | - ø1¼" splined 14T ANSI B92.1 - 1976 / Frezelenmiş |

Pos.6 - Shaft Seal Version / Sızdırmaz Şaft Veriyonu

omit - Low pressure shaft seal or Standard shaft seal
ihmal - Düşük basınç şaft çantası veya standart şaft çantası
for "...B" shaft

- | | |
|---|--|
| D | - Standard shaft seal / Standart şaft çantası |
| U | - High pressure shaft seal (without check valves)
- Yüksek basınç şaft çantası (tek valfleri olmadan) |

Pos.7 - Drain Port / Sızıntı Hattı

omit - with drain port / Sızıntı hattı ile

- | | |
|---|--|
| 1 | - without drain port / Sızıntı hattı olmadan |
|---|--|

Pos.8 - Ports / Portlar

omit - BSPP (ISO228)

- | | |
|---|---------------------------------------|
| M | - Metric (ISO 262) / Metrik (ISO 262) |
|---|---------------------------------------|

Pos.9 - Special Features / Özel özellikler

Pos.10 - Design Series / Dizayn Serileri

omit - Factory specified / Fabrikada belirtilen

TEKNİK ÖZELLİKLER / SPECIFICATION DATA

Tipi/Type	MR 50	MR 80	MR 100	MR 125	MR 160	MR 200	MR 250	MR 315	MR 400
Displacement / İletilen hacim (cm ³ /rev.)	51.5	80.3	99.8	125.7	159.6	199.8	250.1	315.7	397
Max. Speed (Max. hız) (RPM)	cont./Devamlı	775	750	600	475	375	300	240	190
	int.* / Aralıklı	970	940	750	600	470	375	300	240
Max. Torque (Max. Tork) (daNm)	cont./Devamlı	10.1	19.5	24	30	39	38.5	39	38
	int.* / Aralıklı	13	22	28	34	43	46	58	60
	peak** / Pik	17	27	32	37	46	56	71	83
Max. Output (Max. Çıkış) (kW)	cont./Devamlı	7	12.5	13	12.5	11.5	9	6.5	4.8
	int.* / Aralıklı	8.5	15	15	14.5	14	11.5	10.5	9.6
Max. Pressure Drop (Max. Basınç Düşümü) (bar)	cont./Devamlı	140	175	175	175	175	140	110	90
	int.* / Aralıklı	175	200	200	200	200	175	175	140
	peak** / Pik	225	225	225	225	225	225	225	210
Max. Oil Flow (Max. Yağ Akışı) (l/min)	cont./Devamlı	40	60	60	60	60	60	60	60
	int.* / Aralıklı	50	75	75	75	75	75	75	75
Max. Inlet Pressure (Max. Giriş Basıncı) (bar)	cont./Devamlı	175	175	175	175	175	175	175	175
	int.* / Aralıklı	200	200	200	200	200	200	200	200
	peak** / Pik	225	225	225	225	225	225	225	225
Max. Return Pressure w/o Drain Line or Max. Pressure in Drain (bar) (Dreyn hatsız ve dreyn hattındaki max. basınç)	cont. 0-100 RPM	150	150	150	150	150	150	150	150
	cont. 100-300 RPM	75	75	75	75	75	75	75	75
	cont. 300-600 RPM	50	50	50	50	50	50	-	-
	cont. 600 RPM	20	20	20	-	-	-	-	-
	int.* 0 - max.RPM	150	150	150	150	150	150	150	150
Max. Return Pressure with Drain Line (bar) (Dreyn hatlı max dönüş basınç)	cont./Devamlı	175	175	175	175	175	175	175	175
	int.* / Aralıklı	200	200	200	200	200	200	200	200
	peak** / Pik	225	225	225	225	225	225	225	225
Max. Starting Pressure with Unloaded Shaft, (bar) (Yüklemesiz şaft ile başlama basıncı)	10	10	10	9	7	5	4	3	3
Min Starting Torque (min başlama Torku) (daNm)	at max. press. drop. cont.	8	8	20	25	32	33	31	33
	at max. press. drop. Int.*	10	10	23	28	37	40	48	50
Min. Speed***, (RPM)	10	10	10	10	10	10	10	10	10
weight, avg. (kg)	MP(F)	6.8	6.9	7.2	7.3	7.5	8	8.4	9.1
	MRF	6.2	6.3	6.6	6.8	7.6	7.2	7.8	8.6
	MRQ								

* Intermittent operation: The permissible value may occur for max. 10% of every minute.

** Peak load: The permissible value may occur for max. 1% of every minute.

*** For speed of 5 RPM lower than even, consult factory or your regional manager.

1) Intermittent speed and Intermittent pressure must not occur simultaneously.

2) Recommended filtration is per ISO clean lines code 20/16. A nominal filtration of 25 micron or better.

3) Recommend using a premium quality, anti-wear type mineral based hydraulic oil, HLP (DIN51524) or HM (ISO 6743/4) if using synthetic fluids consult the factory for alternative seal materials.

4) Recommended minimum oil viscosity 13 mm²/s at 50 C.

5) Recommended maximum system operation temperature is 82 C

6) To assure optimum motor life fill with fluid prior to loading and run at moderate load and speed for 10-15 minutes.

* Aralık Operasyonu: İzin verilebilir değerler her dakikanın maks %10 için oluşabilir.

** Aşırı Yük: Müsaade edilebilir değerler her dakikanın %1 için oluşabilir.

*** 10 RPM ve aşağısı hızlar için fabrikaya veya bölge bayiliğine başvurunuz.

1) Aralıklı hız ve aralıklı basınç düşüşleri aynı zamanda olmalıdır.

2) Tavsiye edilen filtrasyon ISO 20/16, nominal filtrasyon 25 mikron ve iyisi.

3) Tavsiye edilen hidrolik yağ üstün kalitede anti-wear tipi mineral kökenlidir.

4) Tavsiye edilen en düşük yağ viskozitesi operasyon sıcaklığının 133 mm²/s'dir.

5) Tavsiye edilen en yüksek sistem operasyon sıcaklığı 82 C dir.

6) En uzun motor ömrünü sağlamak için yüklemeye önce sıvı ile doldurulup

düşük bir yük ve hızda 10-15 dk. çalıştırılır.

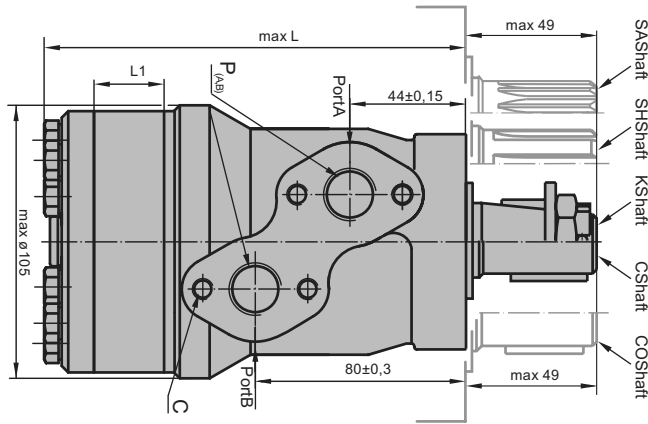

PORTING / BAĞLAMA

Side Ports / Yan Portlar

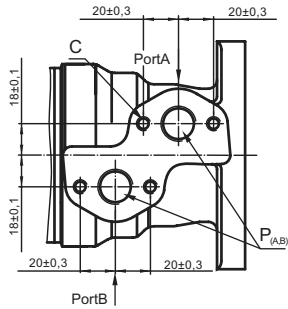

Rear Ports / Arka Portlar

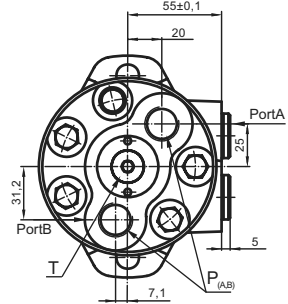

C : 4xM8-13mm depth / derinlik
P_(A,B) : 2x G 1/2 or 2x M 22 x 1,5 - 15 mm depth
T : G1/4 or M14x1,5-12mm depth(plugged)

MOUNTING / MONTAJ

Oval Mount (2Holes) / Oval Şekli (2 Delikli)

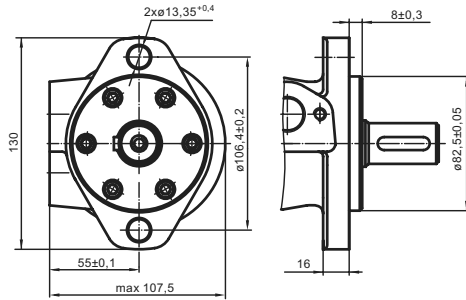

F - Oval Mount (4Holes) / Oval Şekli (4 delikli)

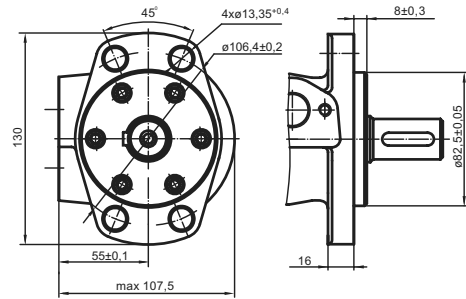

Q - SquareMount(4Bolts) / Kare Şekli (4 civatalı)

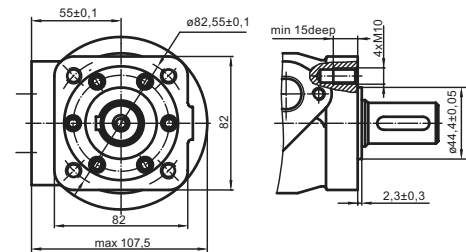

SHAFT EXTENSIONS/ ŞAFT ÖZELLİKLERİ

C - ø25 straight, Parallel key A8x7x32 DIN6885
Max. Torque 34daNm

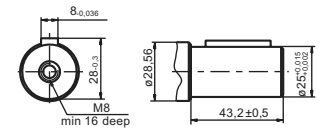

Cb - ø32 straight, Parallelkey A10x8x45 DIN6885
Max. Torque 77daNm

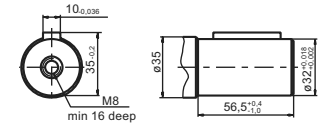

CO - ø1" straight, Parallekey 1/4"x1/4"x1"BS46
Max. Torque 34daNm

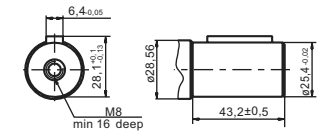

SH - splined, BS 2059 (SAE6B)
Max. Torque 40daNm

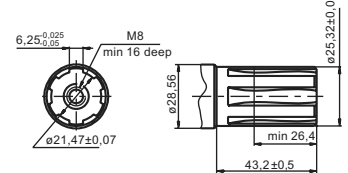

K tapered 1:10, Parallekey B5x5x14 DIN 6885
Max. Torque 40 daNm

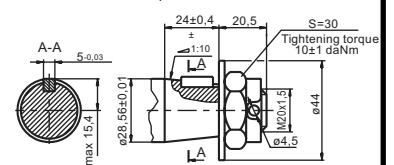

Type/Tipi	L,mm	Type/Tipi	L,mm	Type/Tipi	L,mm	Type/Tipi	L,mm	L ₁ ,mm
MR(F) 50	138,0	MRQ 50	143,5	MR(F)E 50	157,5	MRQE 50	163,5	9,0
MR(F) 80	143,0	MRQ 80	148,5	MR(F)E 80	162,5	MRQE 80	168,5	14,0
MR(F) 100	146,0	MRQ 100	152,0	MR(F)E 100	165,5	MRQE 100	171,5	17,4
MR(F) 125	150,5	MRQ 125	156,5	MR(F)E 125	170,0	MRQE 125	176,0	21,8
MR(F) 160	156,5	MRQ 160	162,5	MR(F)E 160	176,0	MRQE 160	182,0	27,8
MR(F) 200	163,5	MRQ 200	169,5	MR(F)E 200	183,0	MRQE 200	189,0	34,8
MR(F) 250	172,0	MRQ 250	179,0	MR(F)E 250	192,0	MRQE 250	198,0	43,5
MR(F) 315	183,0	MRQ 315	189,0	MR(F)E 315	204,0	MRQE 315	210,0	54,8
MR(F) 400	198,0	MRQ 400	204,0	MR(F)E 400	218,0	MRQE 400	224,0	69,4